



Butterfly Embroidery Machine

B1201B/T Single Head 12 Needle

Manual

© Copyright 2010:

TheEmbroideryWarehouse



TheEmbroideryWarehouse

© 2010 TheEmbroideryWarehouse

PO BOX 11977
Fort Worth, Texas

All rights reserved. No part of this manual may be reproduced, transmitted, or viewed in any form or by any means without permission in writing by its publisher.

Version 1.1F

Table of Contents

About this document	5
About this document	5
General Information	6
About the Machine	6
Compatible Design Formats.....	6
Type of Embroidery Applications.....	6
Warranty and return policy	7
Contact and technical information	7
Setting up your equipment	9
Included with your equipment	9
Getting to know your machine	10
Out of the crate setup.....	12
Setting up stand (cart)	12
Placing machine on stand (cart).....	12
Setting up thread rack (tree).....	12
Setting the threads (spools).....	13
Threading and tensions of your machine	15
Upper thread threading	15
Upper Thread Tension	18
Bobbin thread	19
Bobbin Thread Tensions.....	20
Hooping.....	21
Setting up the tubular arms	21
Hooping a tubular hoop.....	21
Using the Control Panel	23
About the control panel.....	23
Maintenance	24
Oiling	24
Oil Point Breakdown	25
Glossary.....	26
Glossary.....	26

Frequently Asked Questions	27
FAQS	27
Specifications	28
Machine specifications	28
Troubleshooting and Technical Support	29
Technical Support	29
Troubleshooting	29
Pictures	30
Pictures & Videos	30
Part Book	31
Parts Book	31
Table Top	33
Rotary Hook Base	35
Trimmers	37
Arm	40
Needle Bar Driver	43
Upper Thread Hook	45
Color Change System	47
Needle Case A	49
Needle Case B	51
X-Axis Drive System	53
Y-Axis Drive System	55
Tension Base	57
Thread Stand	59
Bobbin Winder	61
Electronics	63
Hoops / Frames	65
Cap Driver	67
Cap Frame	69
Cart	71

About this document

About this document

This document is to be used as a reference user's manual for the Butterfly B1201B/T – Single Head 12 Needle Embroidery Machine.

We highly encourage you to completely review the entire contents of this manual before setting up or using your embroidery machine.

To download a copy of this manual at anytime, please go to:

http://www.ButterFlyEmb.com/Butterfly_Embroidery_Machine_Manual.pdf

General Information

About the Machine

The Butterfly B1201B/T is a single head (single station) embroidery machine with 12 needles (colors). This allows the user to embroider up to one garment at one time with one needle at a time. The machine automatically color changes (as indicated or preprogrammed by the embroidery machine design). A color change is in essence selecting a different needle with a different color thread in the needle. The machine has a USB port (memory stick) that reads several different embroidery formats. The user manually loads the **pre-digitized** designs into the machine off of the USB port and/or the network when applicable.

Compatible Design Formats

The Butterfly machine work with the following design formats all saved on a standard USB flash (thumb or memory) drive. Instruction on how to save to these formats can be found in your software user manual. If you do not have software that will write to one of the compatible formats, please go to <http://www.MadPunch.com> to download Mad Punch - Free Digitizing / Editing Embroidery Software.

- DST (Tajima Format)
- EXP (Melco DOS Format)

Type of Embroidery Applications

The Butterfly machine is comparable with most all of the major industrial (commercial) embroidery machines. Some embroidery equipment may or may not have special equipment attached to offer additional types of embroidery. The following general list includes several applications where the Butterfly Embroidery Machine might be used. Typically to change from one type of embroidery setting to the next requires the operator to manually change out adapters.

This general list includes but is not limited to:

- Flat Embroidery Work
 - Flat embroidery work typically includes works done when the embroidery machine tabletop (removable on the Butterfly) is left on the machine. This refers to anything typically flat in nature or design such as
 - Drapery
 - Table Cloths
 - Aprons
 - Yard goods (yard referring to a measurement of fabric/material)
 - Etc
- Tubular Embroidery Work
 - Tubular Embroidery Work typically refers work that is done with the removable tabletop removed from the machine. This allows for the embroidery work to be draped down from the machine hanging from the embroidery hoop. Tubular is currently the most popular form because it makes hooping and embroidering

shirts much easier. Hooping a **Tubular Frame** is general much less time consuming and easier than hooping with other types of hoops or frames.

- T-Shirt
- Polos
- Pillow Cases
- Etc
- Cap (270 degree) Embroidery
 - Cap embroidery refers to embroidery done directly on a baseball style cap/hat
 - Baseball Caps
 - Etc

Warranty and return policy

Below is a summary of our warranty and return policy. We highly recommend you to read the full warranty and return policy document.

Our warranty covers up to 2 years on all **non-consumable** parts and electronics one the Butterfly Embroidery Machine. Our warranty does not cover misuse or user damages. To redeem warranty repairs or service, the device must be sent back to our corporate office. Labor is covered for one year via phone support, web support (email, webcam, chat, etc) and in-house (OUR HEADQUARTERS). Labor warranty is automatically voided if the machine is worked on by non-authorized or non-approved parties.

Returns may be accepted for up to 5 days after receiving the equipment. The equipment must be returned in its original packing, undamaged. Full refund will be issued upon returning the device minus ALL shipping costs. A restocking fee may apply.

Contact and technical information

Corporate office:

2954 SE Loop 820
Fort Worth, Texas
76140 / USA
+1-817-346-7691

<http://www.ButterFlyEmb.com>

MAILING:

PO BOX 11977
Fort Worth, Texas
76110 / USA

Parts and Accessories:

<http://www.EmbAccess.com>

Electronics Repairs and servicing:

<http://www.PLRElectronics.com>

Setting up your equipment

Included with your equipment

Included in a standard purchase of the B1201B/T embroidery machine typically includes***:

- Power Cable
- Standard Tool kit with the following
 - Scissors
 - Tweezers
 - Threading Rod
 - Oil Can
 - Philips Screw Driver
 - Flat Screw Driver
 - USB Memory Stick
 - Etc
- Single Head Stand
- Removable Table Top
- Light (typically attached to the machine)
- Border Sash
- Stand (cart)

*** The above list may contain items not included with your particular machine. It is highly recommend getting a complete list from your sales representative. The above list is only a generalization.

Getting to know your machine

Pictures and description of the Butterfly B1201B/T embroidery machine below:

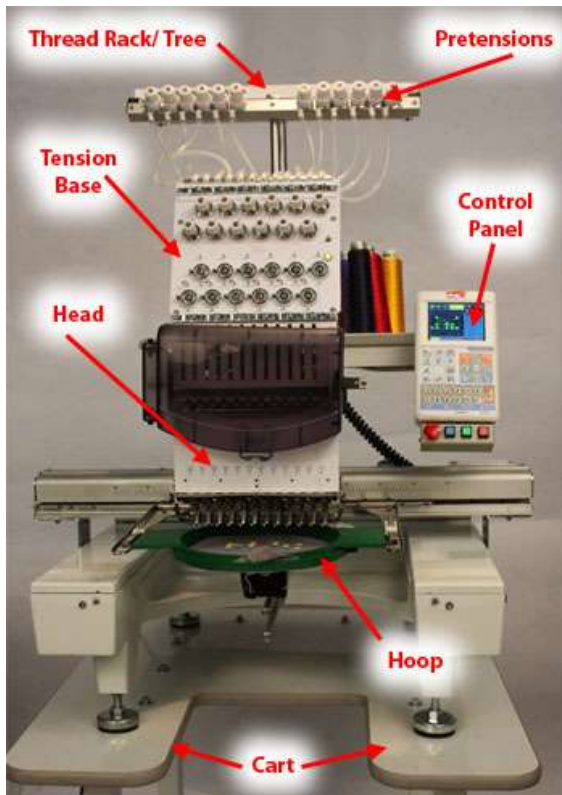

Image 1.A – Butterfly B1201B/T Embroidery Machine – Single head 12 needle embroidery machine. The machine assembled on the cart/stand. This example is with the tubular hoop attachment installed and the removable table removed.

Image 1.B – Control panel – The control panel is where the entire machine is controlled. This includes your Stop, Start, Emergency Stop and Power button at the bottom of the machine. On the right side of the machine is the USB port for inserting a USB memory stick for inputting designs into the machine. The Speed Up and Speed Down button are used to control the embroidery speeds of the machine during operation. The recommended speed to run the machine is between 600 – 800 stitches per minute. The same buttons also double as back and forward buttons for the menu, etc.

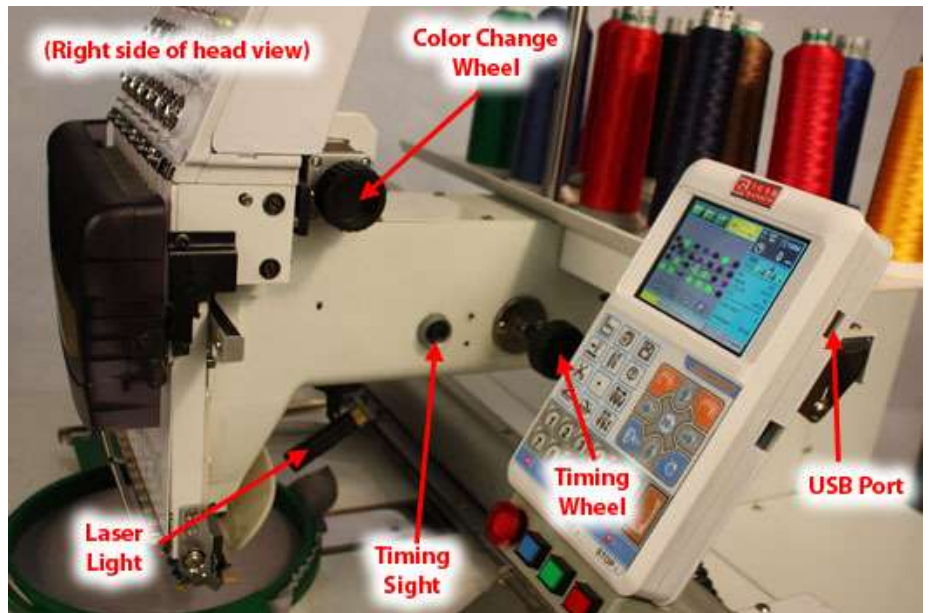
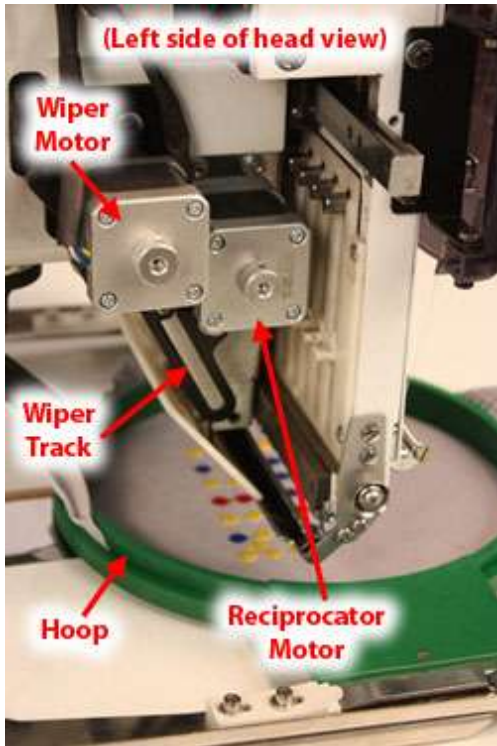

Image 1.C – Head Left Side – View looking to the left side of the embroidery machine. Various motors are shown on the left side of the machine. The wiper motor control the wipers which grab the embroidery thread after the thread is cut. The reciprocator motor is what controls the arm which grabs the needle bar and moves it up and down.

Image 1.D – Head Right side – View looking to the right side of the embroidery machine. The color change where is used to move the head to the left or to the right (to different needles). The timing sight is a glass window you can view the timing numbers through (for setting machine parameters during maintenance). The timing wheel moves the needle bar through its cycles from 0 to 360 degrees. The laser light is used to highlight the needle plate hole or, the point at which the embroidery machine needle makes penetration.

Out of the crate setup

If your equipment has been shipped to you then there are certain steps you will need to take to uncrate and setup. The steps may vary from machine to machine and crate to crate.

SEE SUPPLEMENT GUIDE

Setting up stand (cart)

SEE SUPPLEMENT GUIDE

Placing machine on stand (cart)

SEE SUPPLEMENT GUIDE

Setting up thread rack (tree)

SECTION A - Assembly of the Thread Rack (also known as the Threading Tree) – See Image 1. The thread rack is the part of the machine which includes the first set of tension knobs. The primary function of the thread rack is to smoothly unwind thread off of the spool of thread.

Step 1 – Screw Thread Stand Shafts (2 pcs) in by hand into threaded holes A and B on the Thread Stand.

Step 2 – Tighten thread shafts using the flat adjustor C on each shaft with a wrench.

Step 3- Place the Thread Rack/Tree onto thread stand shafts with the knobs of the thread rack facing towards the head (front most

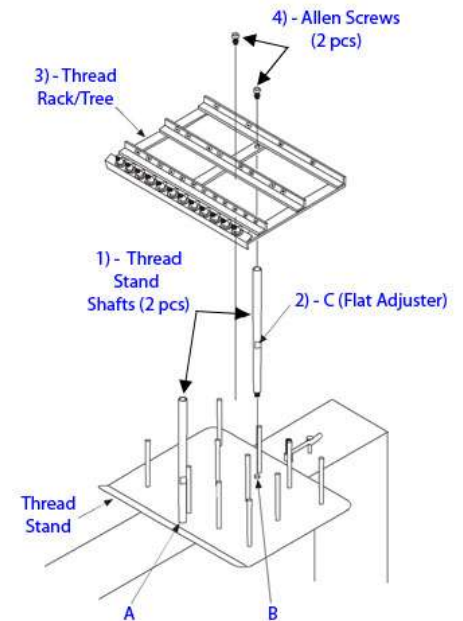

Image 1 – Thread Rack

part of the machine)

Step 4 – Tighten Allen screws on top of the thread rack.

SECTION B- Assembly of the threading tubes. – See Image 2. The primary functions of the thread tubes are to keep the threads from raveling together under wind, etc.

Step 1 – Insert a Thread Tube Joint (end of a Thread Tube) into the top U-SLOT. Start by inserting one end of one tube in U-Slot A1. A1 is located on the Thread Rack.

Step 2 – Insert the other end of the Thread Tube into A2. A2 is located on the machine head, on the Tension Knob Base.

Step 3- Proceed by installing each thread tube in the same manner.

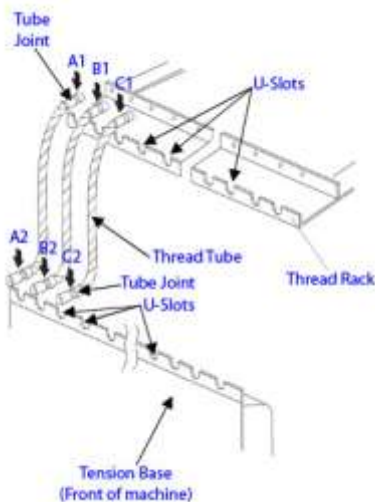

Image 2 – Thread Tubes

Setting the threads (spools)

The Butterfly B1201B/T is a 12 color machine meaning it can hold up to 12 different spools of thread. Generally most users will use 12 different colors of thread designating at least 6 of the colors for basics such as white, black, red, blue, green, yellow, etc. There are various brands and types of threads.

The most common types are **Rayon** and **Polyester**. Rayon is a softer but weaker thread. Typically polyester (or “poly”) is recommended due to its strength which also reduces thread breaks.

Step A – Begin by placing 12 spools of thread on the thread stand.

Step B – Take the first spool (1) thread and pass it through eyelet ‘2’ in the image followed by ‘3’ then ‘4’.

Step C – Take the second spool (5) thread and pass it through eyelet ‘6’ in the image followed by ‘7’.

Step D - Take the third spool thread (8) and pass it through eyelet ‘9’ in the image

Step E – Continue with the next spool in sequence (to the right of spool 1). Continue till the entire thread rack is threaded.

You can choose to thread the tension knob while threading the thread rack or, wait till the entire thread rack is threaded and then thread the rest of the machine (proceeding pages).

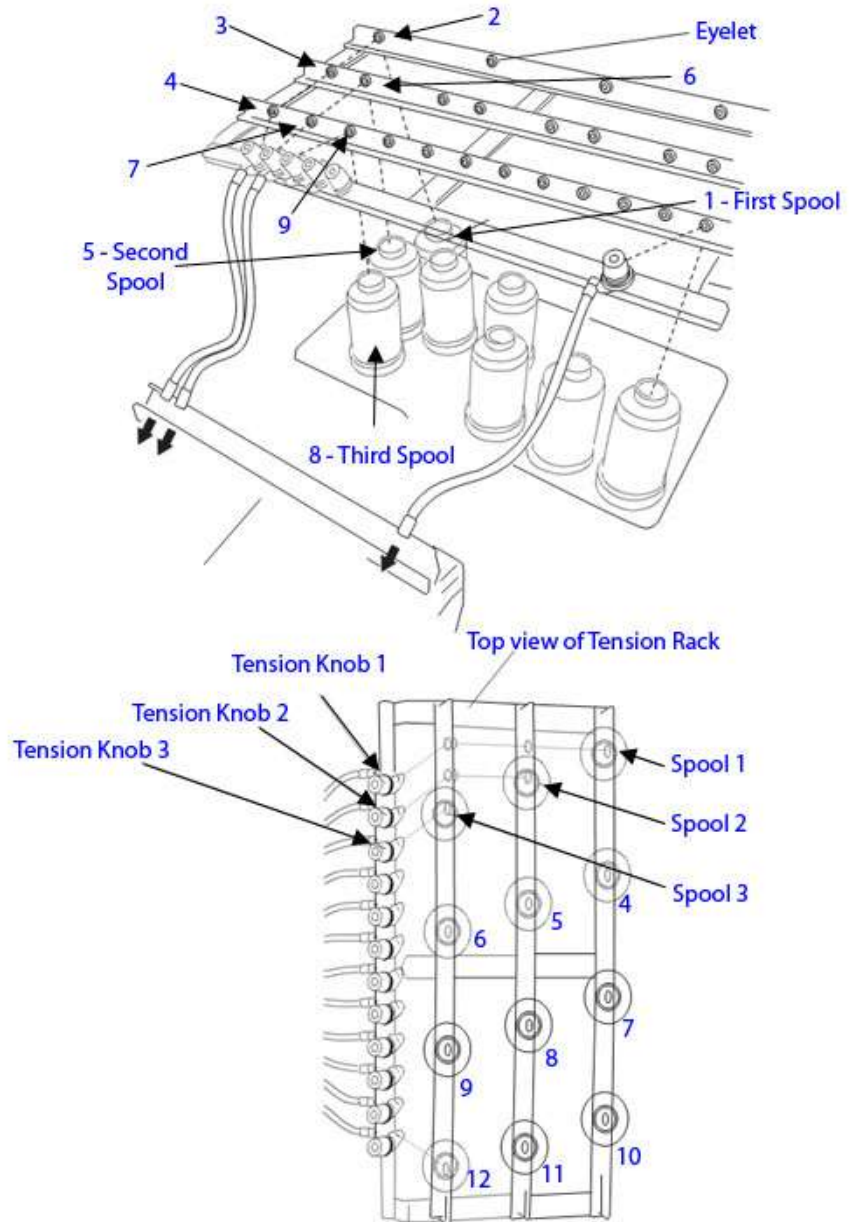

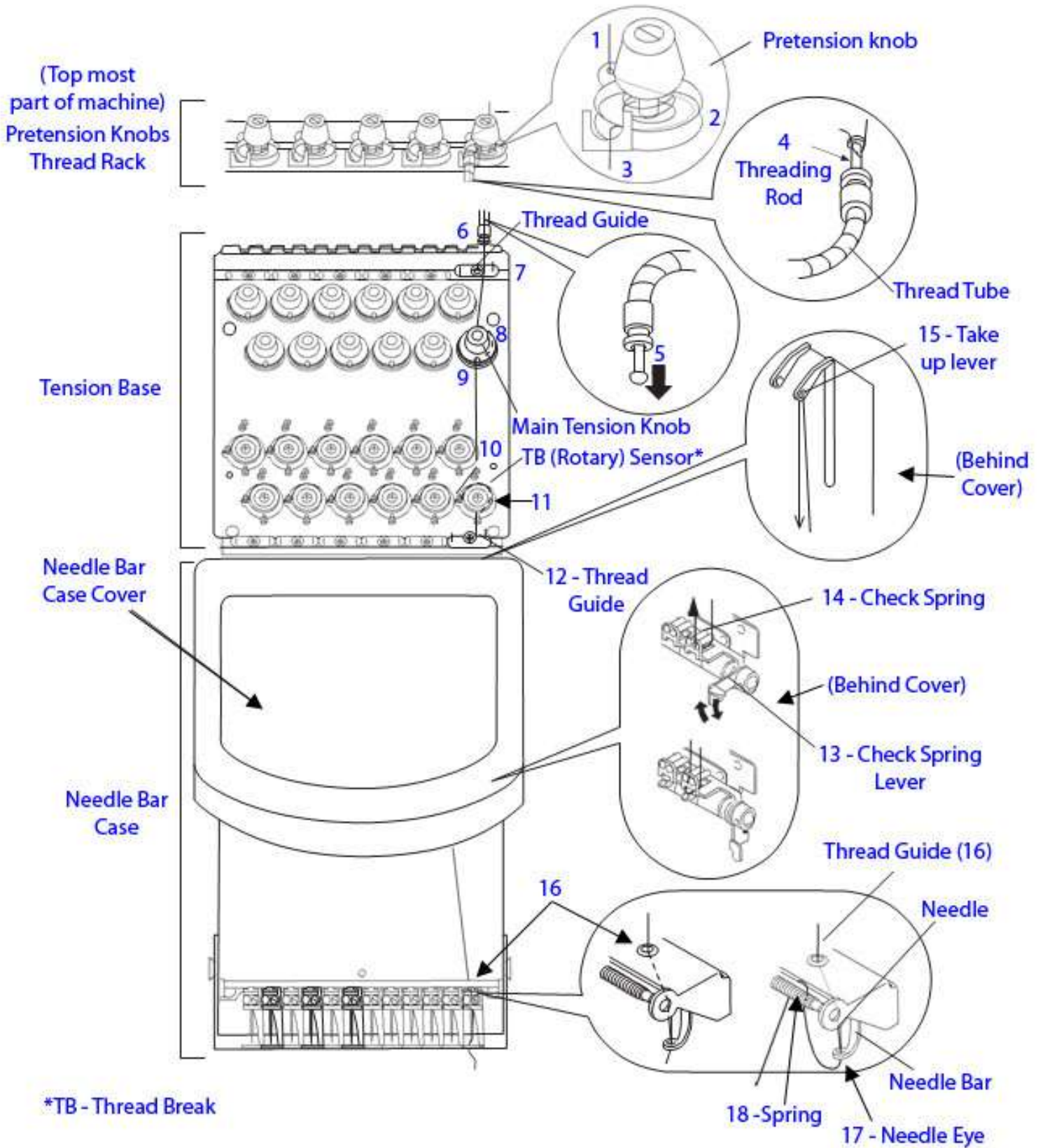

Image 3 - Threading

Threading and tensions of your machine

Be sure you have already completed the previous sections before proceeding. See previous Images 3. Proper threading and **tensions** of your embroidery machine are essential to production, thread breaks, and final embroidery quality. Without properly threading your machine and setting the correct tensions per spool, needle and bobbin, your machine may not run. It is very important that the threading tracks and tensions are constantly checked.

Upper thread threading

The upper thread refers to the thread that is seen on the top of the embroidered item. The upper threading track is shown in Image 3. An **upper thread break** typically refers to when the current spool of thread that is embroidering, has broken. Upper thread is also physically located at the top of the machine whereas the lower thread (bobbin) is located towards the bottom. Upper thread is the common spool of thread used to embroidery designs.

Refer to Image 3 to thread.

Step A – First complete the section *“Setting the threads”*.

Step 1 – Insert the first thread into the eyelet of the pretension knob. The pretension knob is the one at the very top of the machine and is the first tension knob the thread passes through

Step 2 – Place the thread in between the 2 disks of the pretension knob going to the right.

Step 3 – Detach the top of the thread tube and place thread through U-Slot

Step 4/5/6 – For this step you will need the **threading rod**. The Threading Rod is a narrow piece of plastic approximately 2 feet long about the width of a pencil tip that comes with the standard tool kit. If you do not have a threading rod, you can also use a guitar string or anything similar. On the end of the threading rod, there is a cut out notch. Insert the threading rod from the bottom of the threading tube, notch end first. Pass the threading rod through the entire threading tube until the notched end comes out. Attach the thread to the notch and (5) pull the other end of the threading rod back out of the threading tube so that the thread is completely through the tube. (6) Attach both ends of the threading tube back onto the machine.

Step 7 – Pass the thread under the thread guide. The thread guide is a piece of metal loosely attached to the machine by a screw and spring. The function of the thread guide is to unravel threads that might still be raveled and to keep threads going straight in their designated paths.

Step 8 – Pass the thread through the main tension knob in the same manner as it goes through the pretension knob

Step 9 – Place thread to the left of the guide rod

Step 10 – Place thread to the right of the guide rod on the rotary wheel, and then under the next guide rod to the left of the rotary wheel. The rotary, or Thread Break wheel, is used to detect

thread breaks. If your machine is giving false thread breaks, first check that this wheel is properly threaded. If this wheel is properly threaded, check the entire thread track for any mistreading.

Step 11 – Place thread over the rotary wheel and then to the right of the wheel and then to the left of the next thread guide rod. If your machine is detecting false thread breaks but threaded properly, you might try wrapping the thread around the rotary wheel a second time.

Step 12 – Place thread under the next thread guide.

Step 13 – Open the head case cover. To the right of the machine behind the cover, on the head, there is a lever that goes up and down. Push the lever down as far as it goes. When you do, you will see several (12) small wires/springs. These are known as the **Check Springs**.

Step 14 – Place the thread to the right of the right most cylinder rod where check springs come out of when the check spring lever is pressed down. Place the thread through the check spring eyelet from the right to the left. Bring the thread back up to the left of the leftmost rod corresponding to the current thread you are threading. Move the lever so that the checks springs go back up all the way and then bring it back down about 1mm to give the springs a little bit more spring than if they were all the way up. Not placing the check springs in the correct position will cause trimming problems and problems when changing colors.

Step 15 – Bring the thread back up about 3 inches into the take up lever eyelet.

Step 16 – Bring the thread back down, past the check spring to the bottom of the head and through the last thread guide/eyelet

Step 17 - Place the thread through the needle eye from the front to the back. It is recommended that you cut the thread at a 45 degree angle to give it a point. Once you cut the thread, use your fingers to straighten out the end. Hold the thread with your index and thumb leaving about 1 – 1 ½ inches out keeping the thread at straight as possible as you pass it through the needle. Once thru the needle, pass it through the needle bar hole.

Step 18 – Place the thread in between the long spring at the bottom of the machine. There is no need to wrap it in the spring and it is recommended placing it into the spring gently without much tension. The spring is only used to temporarily hold the thread. Cut the thread at the end leaving about 1/3 inch extra.

Step B – Continue with the next spool of thread, threading in the same manner as the previous thread.

Further examples are shown on the next page.

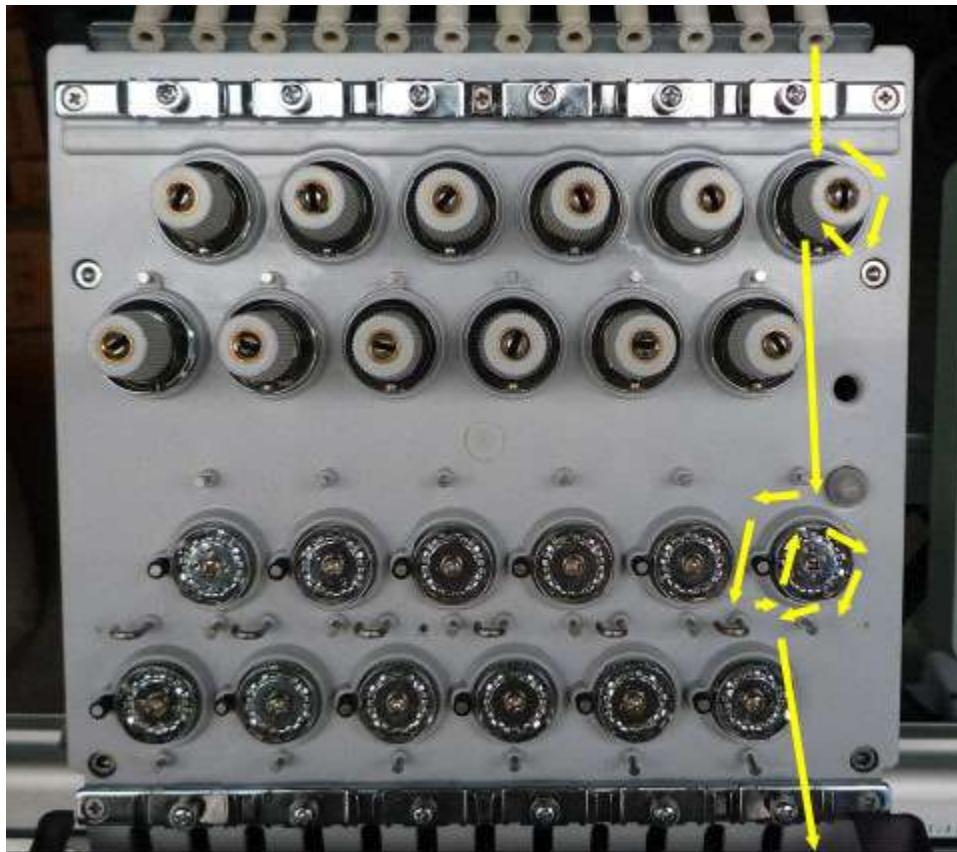
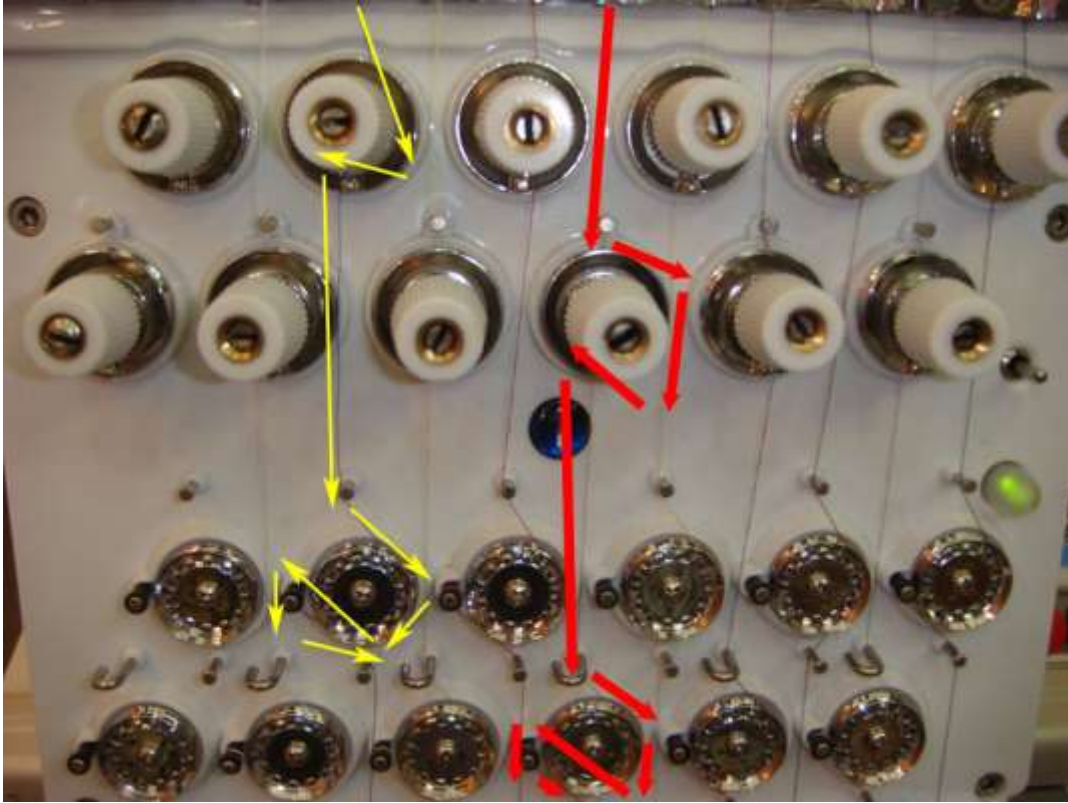

Upper Thread Tension

The upper thread tension refers to how tense or tight the thread feels when you pull it through the very last thread guide eyelet when the thread is properly threaded. There are many metrics for measuring this. However, the final metric usually just depends on what the final embroidery looks like.

Upper thread tension is completely different between one cone and the next and the tensions change as the thread is used. Therefore, the tensions must constantly be checked. Because the B1201B/T has 12 needles and only one bobbin, it is always best to preset the bobbin tensions (next section) first and then change the upper threads to conform to the bobbin tension. In other words, once the bobbin is set, it should not be adjusted much. Each time the bobbin is changed, it may need to be set again. The operator should always recheck bobbin tensions when changing the bobbin (next section).

When pulling the upper thread from the final thread guide eyelet hole (NOT through the needle), the tension on the thread should feel about the same as if the other end of the thread was tied to 3 US Quarters (\$0.75), being dragged across a smooth surface. Generally you should start with tightening both tension knobs at about 50% and then slowly adjusting from there. Once everything is set, you should only adjust with the second tension knob located on the tension base. Minor adjustments during and after embroidery will be required and should only be done with this second knob.

When the machine is embroidering (assuming the bobbin tension is set) you can visually tell if the tensions are set or need adjusting. It is common (and required) to make minor adjustments often. If the thread appears to be loopy then the tension knob needs to be tightened. Typically it takes about $\frac{1}{2}$ turn to make even a slight difference. If the thread appears too tight and/or there are a lot of thread breaks, then the tensions need to be loosened. It is recommended during the first run of a design to slow the machine speed down as slow as possible and make minor adjustments to the tension while slowly speeding the machine up until the tensions are correct. If bobbin thread is coming up on the top of the embroidery then the upper thread may be too tight assuming the bobbin is set correctly. If the bobbin is not set correctly, then the bobbin might be too loose.

There are several other ways to test tensions. One is referred to as the 'H' or 'I' or 'Column' test. In this test, once the embroidery is completed, look underneath the embroidered item. Columns of embroidery such as the column of an 'I' should be $\frac{1}{3}$ bobbin with $\frac{1}{3}$ thread on each sides of the bobbin.

- If the bobbin is correctly set
 - o Too much bobbin (more than $\frac{1}{3}$ of the column)? – Loosen upper thread
 - o Too little bobbin (less than $\frac{1}{3}$ of the column)? – Tighten upper thread
- If the bobbin is not set
 - o Too much bobbin (more than $\frac{1}{3}$ of the column)? – Tighten bobbin
 - o Too little bobbin (less than $\frac{1}{3}$ of the column)? – Loosen bobbin

Bobbin thread

The B1201B/T uses style 'L' bobbins and bobbin cases which are also known as Standard Bobbins. We recommend using prewound polyester bobbins with cardboard sides. The bobbin is located inside the bobbin case and is near the bottom of the machine under the needle plate. The bobbin should be cleaned and replaced regularly to ensure proper tensions. Lint typically clogs the bobbin case which will produce variations in tensions and poor embroidery quality. It's a good indication that it's time to replace the bobbin case if the bobbin pulls out of the bobbin case rough after the case has been cleaned. Because bobbin cases are so inexpensive, it is recommended to purchase new ones rather than replace or repair used ones.

To remove the bobbin case from the **hook** of the machine, pull the bobbin case handle while extracting the case. When inserting the bobbin case back into the hook, make sure that the handle is pointing straight to the right. Do not pull the handle when inserting the case back into the hook.

To thread your bobbin into the bobbin case, follow the following steps.

Step 1 – Insert the style 'L' prewound standard cardboard sided bobbin into the bobbin case.

Step 2 – Insert the bobbin thread into the slot/notch on the side of the metal bobbin case.

Step 2/B – When pulling the bobbin thread through the notch, the bobbin should spin clockwise when looking at the side/top of the bobbin. If it is not spinning clockwise, remove the bobbin and flip it over.

Step 3 – Pull the bobbin thread through the notch and under the hook located right by the notch.

Step 4 – Place the thread under the pig tail of the bobbin case. Be sure that the bobbin thread passes from the bottom opening of the pig tail and exits for the very top and not from the side of the pigtail.

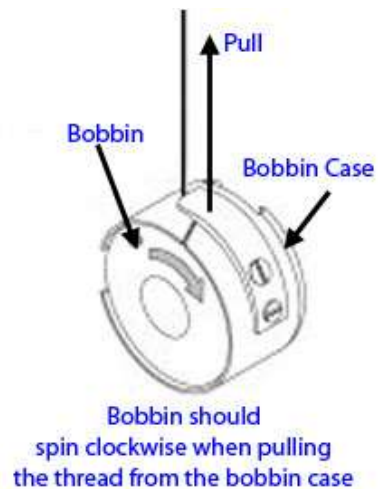
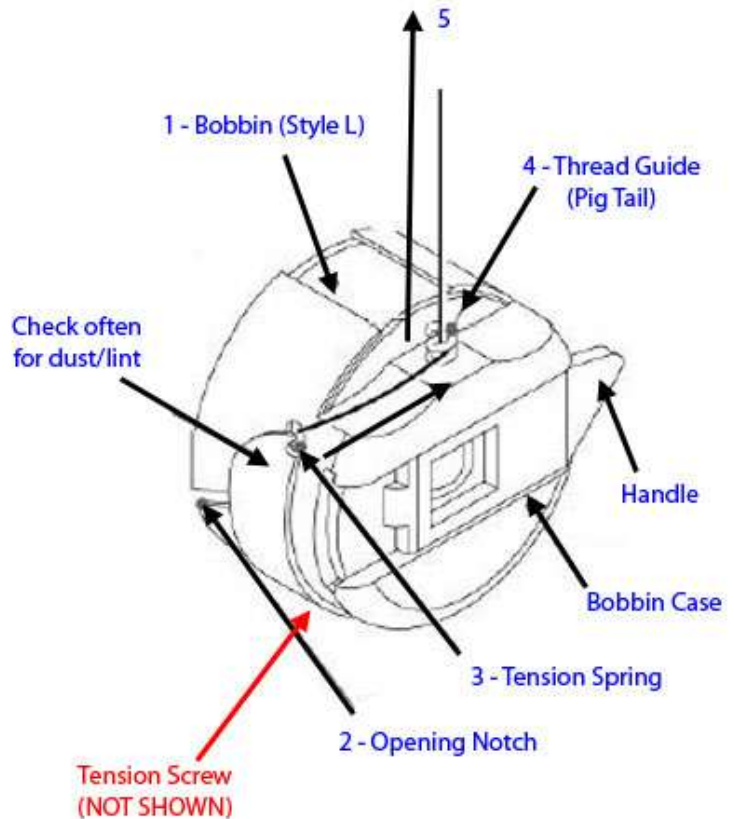

Step 5 – Pull the bobbin thread out about 6 inches while checking tensions (next section). Adjust if needed.

Step 5/B – Always check tensions on the bobbin when replacing it. The bobbin lasts approximately 32,000 stitches. Bobbin tensions might vary from bobbin to bobbin and the tension does change as the bobbin is used.

Bobbin Thread Tensions

The bobbin thread tension is typically considered much more important than the upper thread tension because all 12 needles depend on the tensions of the bobbin in order to embroider properly. It is important to set the bobbin tensions one time and try not to adjust it per color but rather adjust each other color/needle to conform to the bobbin. The bobbin tensions might need to be changed when replacing the bobbin and should be checked regardless. The operator should check the tensions of the bobbin after each run by looking at the bobbin of the final embroidery product for excess or shortage of bobbin thread. Generally on a column stitch 1/3 of the column should be bobbin thread and the other 2/3 upper thread.

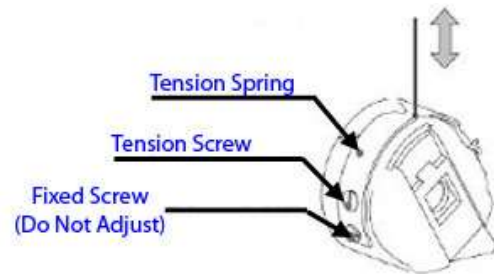

An adjuster screw is located on the tension spring. Next to the adjuster screw is a fixed screw that holds down the tension spring. This fixed screw should never be touched. Tightening (turning clockwise) will tighten the tension of the bobbin. When tightening the bobbin, less bobbin thread will show underneath the final embroidered item. Loosening (turning counterclockwise) will lessen the bobbin tension. When loosening the bobbin, more bobbin thread will show underneath the final embroidered item. The bobbin tension should be set about the same as the upper thread tension. The same example of the 3 quarters (\$0.75) can be applied. Another way to check tension is to hold the bobbin thread and drop the bobbin case. The case should fall approximately 1 – 3 inches. If it falls too far, the tensions need to be tightened. If it falls too short, tensions will need to be loosened. However, that is only an example and tensions will vary from bobbin to bobbin and from bobbin case to bobbin case. The only way to set the tension accurately is by eye, based on the final embroidery quality.

*Note - If you are using a bobbin case tension gauge the approximate setting should be between 25-35 grams

Hooping

Setting up the tubular arms

The **tubular arms** are what hold the **tubular hoops** onto the machine. The tubular arms attach to the machine onto the **pantograph**. The tubular setup is the most common type of embroidery used on these types of machines. The tubular system utilizes the tubular hoops. The tubular system is most common because it's a much quicker and easier way to hoop.

To use the tubular system you will need to first install the tubular arms if they have not already been installed. To install the tubular arms start by sliding the left tubular arm into the pantograph into one of the slots on the left side of the pantograph (1). There are several slots on the pantograph for different size of hoops. It does not

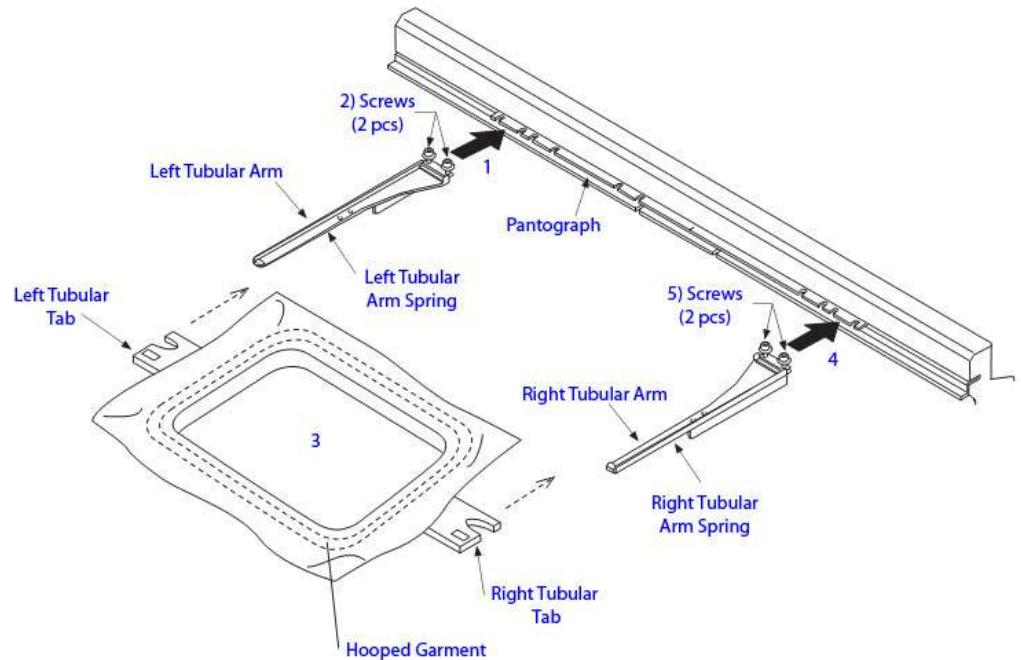

matter which slots are used as long as the hoop will fit once both arms have been installed. (2) Slightly tighten the 2 screws on the tubular arm, onto the pantograph. The next step will be to select the hoop size you would like to use (3). Many embroidery machines such as the Butterfly will accept large, medium and small hoops. Large hoops are overall larger from the far left tab to the far right tab where as small hoops are smaller from one tab to the next. On standard size hoops (which might be 9cm, 12cm, 15cm, 18cm, etc) the length from one tab end to the next is 360mm. Once you select the hoop size, measure the hoop from tab to tab. Next install the right tubular arm (4) in the slots on the pantograph the same distance away from each other as the length of the hoop. Slightly tighten (5) the 2 screws on the tubular arm. It is recommended that you then place the hoop into the tubular arms to ensure it fits correctly and that the arms are not at an angle. On each of the tubular tabs, there are sides that have beveled ends. These beveled ends slide into the tubular arm springs at a 30 – 45 degree angle. Place the hoop into the tubular arms under the tubular arm springs. It is not necessary to have anything hooped into the hoop at this time. Check that the arms are not angled and then tighten the 4 tubular arm screws (2) & (5).

Hooping a tubular hoop

Tubular hoops are the most common type of hoops used in commercial embroidery machines. They are very easy to hoop compared to the alternatives and are ideal for embroidery on assembled

goods such as shirts, etc. Embroidery on unassembled goods (raw fabric) is typically best done with other types of hoop systems but most all embroidery done commercially will be on assembled garments. There are many guides available on the internet and in other embroidery training manuals that explain the best way to hoop certain items depending on sizes, sex, type, etc of the garments. This manual will not get into the techniques and it is recommended that the operator search on the internet for further training.

However, when using a tubular hoop as shown the outer ring (piece without the metal tabs) goes inside

or under the garment. For example, on a t-shirt the outer ring will go inside the shirt around the area that is to be embroidered. **Backing or Stabilizer** is then place on top of the outer right in between the garment. The top part of the hoop is then place on top of the garment, inside the outer ring. The top part of the hoop includes the beveled tabs. The beveled part of the tab will always be on top. The garment should be hooped so that the final embroidery imaged is parallel with the beveled tabs.



Using the Control Panel

About the control panel

Maintenance

Oiling

To ensure your Butterfly Embroidery Machine lasts a long and healthy life, it is recommended to oil the machine when required.

Although it is recommended oiling the machine, it is highly discouraged to over oil the machine as the oil can accumulate over electronics, the garments, and other parts that are not designed to be oiled. It is also not recommended to oil parts not specified in this guide. Standard sewing or embroidery machine oil should be used. It is recommended to oil the machine after each shift to give the oil time to settle. When starting the machine at the next shift for the first time, it is recommended to sew a sample run and to sew each run using *solvly*. Solvly helps to catch any excess oil from dripping on and staining the garments.

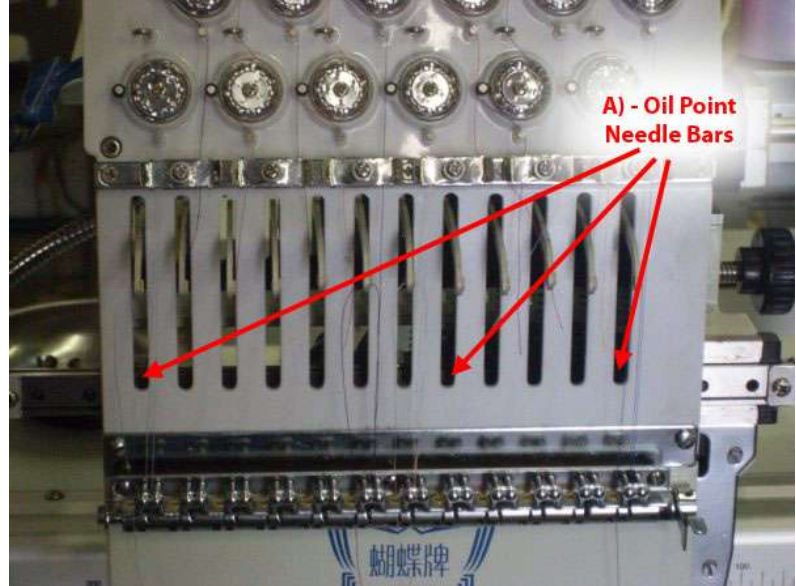

A) – Needle bars – Once every (20) hours of embroidery. Oil each bar through the opening. Do not place more than one drop per bar per 8 hour shift. There is a felt piece inside that head that absorbs the oil and lubricates the shafts.



B) – Rotary Hook – Once every (4) hours of embroidery. It is recommended to oil the hook once at the beginning of the day and then once each (4) hours after. The oil point of the hook (basket that holds the bobbin case) is at the very top of the hook directly under the needle plate. It is not necessary to remove the needle plate if the oiler has a stray. The oil goes between the inner basket that stays stationary and the outer part that spins during embroidery. You will see the hook point at the bottom. Turn the hand-wheel on the right side of machine to move the hook point to the 10 o'clock position. This will place the top of the raceway at about 9 o'clock. Place one drop at top of race at side of basket. Next, press the stop button. This will cycle the machine to a proper head up position.

Do not place more than one drop per needle bar per 8 hour shift. It is recommended to remove the bobbin case when oiling and run a few trims without the bobbin in the case to circulate the oil. If you embroidery machine start to make a constant clicking sound it is usually due to a lack of oil on the hook.

C) – Upper Head Assembly (Reciprocator Shaft) - Once every (16 - 32) Hours of embroidery. The Reciprocator shaft is what the reciprocator rides up and down on. The shaft is not easily accessible directly from the front of the machine so, you must access it from the sides through troughs on the head. To access these troughs, either move the head all the way to needle number 1 or to needle number 12. If you are on needle number 1, the trough will be accessible from the right side of the head. If you are needle number 12, the trough will be accessible from the left of the head. A couple drops should fill the trough. Move the head to the opposite and place a couple more drops on that opposite side.



D) – Oil Stickers – As indicated on the sticker. There are several oiling stickers/holes noted on the machine. These oiling points should be oil as often and as much as noted on the stickers.



Oil Point Breakdown

- A) – One drop once every (20) Hours of embroidery
- B) – One Drop once every (4) Hours of embroidery
- C) – One to two drops on each size once every (16 - 32) Hours of embroidery
- D) – As indicated on sticker

Glossary

Glossary

- **Backing** – Foundation used to stabilize and keep garment flat. Most backings are paper like.
- **Bobbin** – Thread used to tie a knot under the embroidery garment which holds down the upper thread
- **Bobbin Case** – Holds the bobbin
- **Check Springs** – Spring used in threading track which removes whiplash during embroidery
- **Consumables** – Consumables are parts used on the machine such as hooks, needles, and bobbin cases, etc that are to be replaced on a regular basis of normal operation.
- **Digitized(ing)** – Digitizing (in embroidery) is the act of converting a logo, design, symbol, etc into an embroidery file readable by embroidery machines and software. A digitized design is one that has all stitches, color changes, trims, etc programmed in so that the embroidery machine.
- **Hook** – Part which ties thread onto the bobbin and makes the embroidery stitch
- **Non-consumables** – Non-consumables are parts that are not designed to be replaced on a general basis such as motors, shafts, etc.
- **Pantograph** – Device on machine that moves hoop in the X and Y direction (left, right, up and down)
- **Polyester** – Type of textile. In embroidery machines, its typically a stronger thread type than Rayon
- **Pre-digitized** – A design that has already been digitized.
- **Rayon** - Type of textile. In embroidery machines, its typically a stronger thread type than Polyester
- **Solvly** – A plastic like sheet sometimes used on top of embroidery very similar to cellophane. Used to add more foundation on the embroidery. Typically dissolves under water.
- **Stabilizer** – See **Backing**
- **Tensions** – In embroidery, typically refers to how tight the thread feels when pulling it through a threaded machine or through the threaded bobbin. Improper tension will cause both false and actual thread breaks, and poor final embroidery quality among many other problems.
- **Threading Rod** – Used to thread embroidery thread through the embroidery tubes.
- **Topping** – Used on the top of a garment such as solvy.
- **Tubular Arms** – Arms that attach to the pantograph. The tubular hoops then attach to these arms
- **Tubular Hoop/Frame** – A special type of hoop consisting of a plastic ring and another plastic piece that goes into this ring. This hoop has a metal clip which speeds up the process of loading the hoop into the machine.
- **Upper Thread Break** – Typically refers to the current spool of thread that is embroidering, has broke.
- **Wash-a-Way** – See **Solvly**

Frequently Asked Questions

FAQS

- How does the Butterfly B1201B/T compare to other commercial/industrial embroidery machines? **The Butterfly B1201B/T will benchmark against any other machine in its class. The final embroidery quality is just as good as any other machine run under the variables (design type, thread quality, etc).**

Specifications

Machine specifications

Listed below are common specifications of the Butterfly B1201B/T embroidery machine

Belts	Italian
Bobbin Size / Style	Size / Style 'L' or Standard. Prewound polyester recommended
Cap System	270 Degree
Color Changes	Automatic or Manual
Dimensions	Approximately 3' x 3' x 3' without stand
Display	4" Color LCD Display
Embroidery Area	40cm x 50cm ~(15in x 16 in)
Flat Embroidery	Yes
Heads	1
Input	USB / Network (on certain models)
Languages	English / Español (Spanish)
Make	Butterfly
Memory Capacity	16,000,000 Stitches or 500 designs
Model	B1201B/T
Needles	12
Needle sizes (recommended)	Standard 75/11 titanium for most applications but works with most any industrial embroidery machine type. Different needs recommend on different applications such as leather goods, etc.
Oil Type	Standard sewing/embroidery machine oil
Power	110W factory. 220w available on order.
Reciprocator Driver	Pulse Motor
Solenoids	Japanese
Speed (max)	1000 (Stitches/Minute)
Table Top	Removable
Trace	Yes
Trimmers	Yes
Tubular	Yes
Weight	Approximately 100kgs (~220lbs)
Wiper Driver	Pulse Motor

Troubleshooting and Technical Support

Technical Support

Please direct all technical questions to support@butterflyemb.com

You may also try our live support by going to <http://www.ButterFlyEmb.com> and clicking the LIVE SUPPORT icon.

Troubleshooting

Symptoms	Resolution
False thread breaks	-Ensure the machine is properly threaded.
Noise – Clicking Sound	-Oil Hook
Power up – Machine does not turn on	-Ensure that the power cord is securely attached to a 110V outlet and that the 110V outlet is outputting power. -Check fuses.
Thread Breaks	-Poor quality or old thread -Timing issue -Dull, bent, burred, etc needle -Check for any burs in thread track (eyelets, etc)

Pictures

Pictures & Videos

High quality pictures and videos can be found by going to <http://www.ButterFlyEmb.com> and clicking on either the PHOTOS or VIDEOS tab.



Part Book

Parts Book

Butterfly Embroidery Machine

B1201B/T Single Head 12 Needle

Parts Book (Manual Addition)

© Copyright 2010:

TheEmbroideryWarehouse

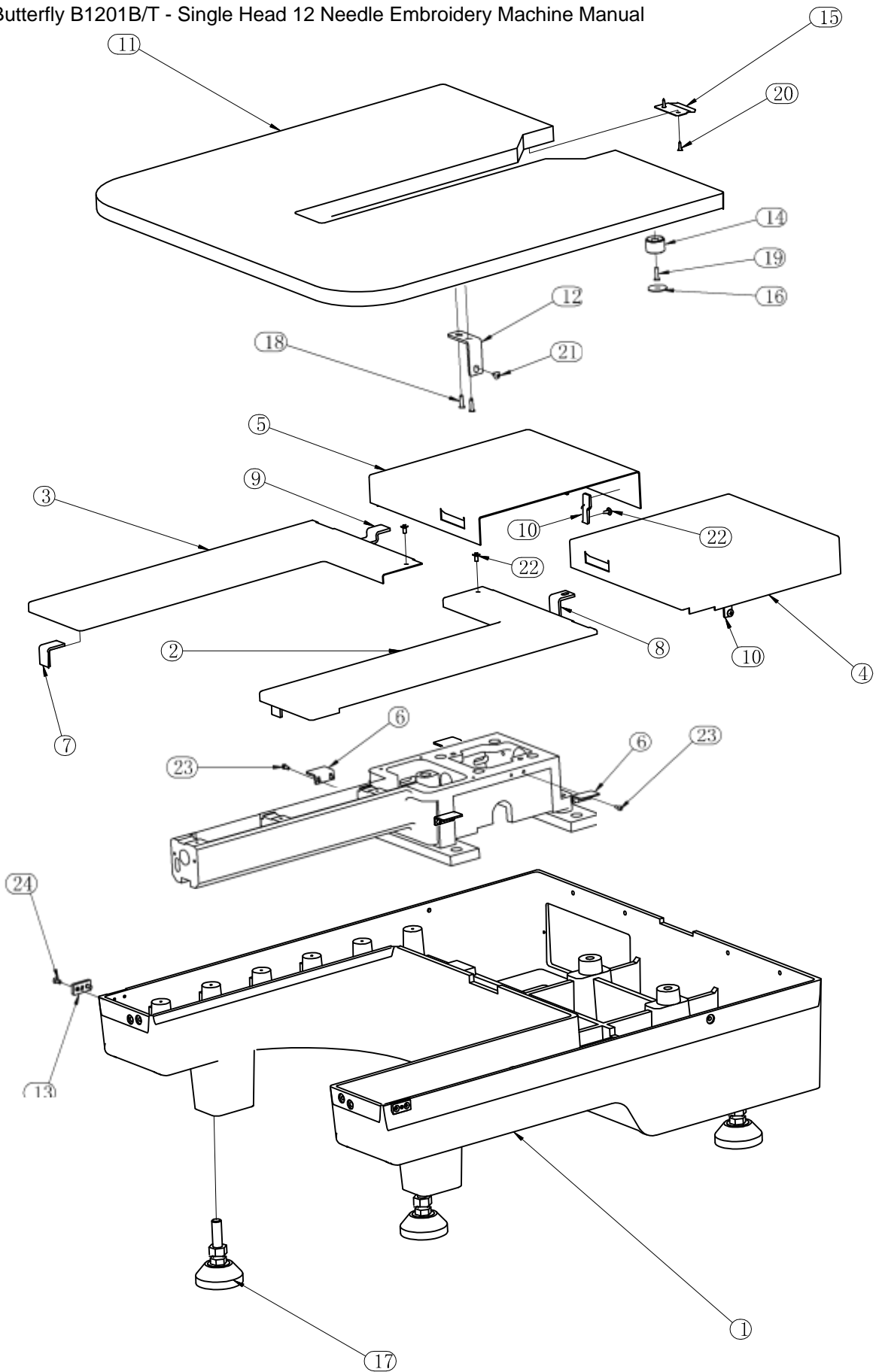
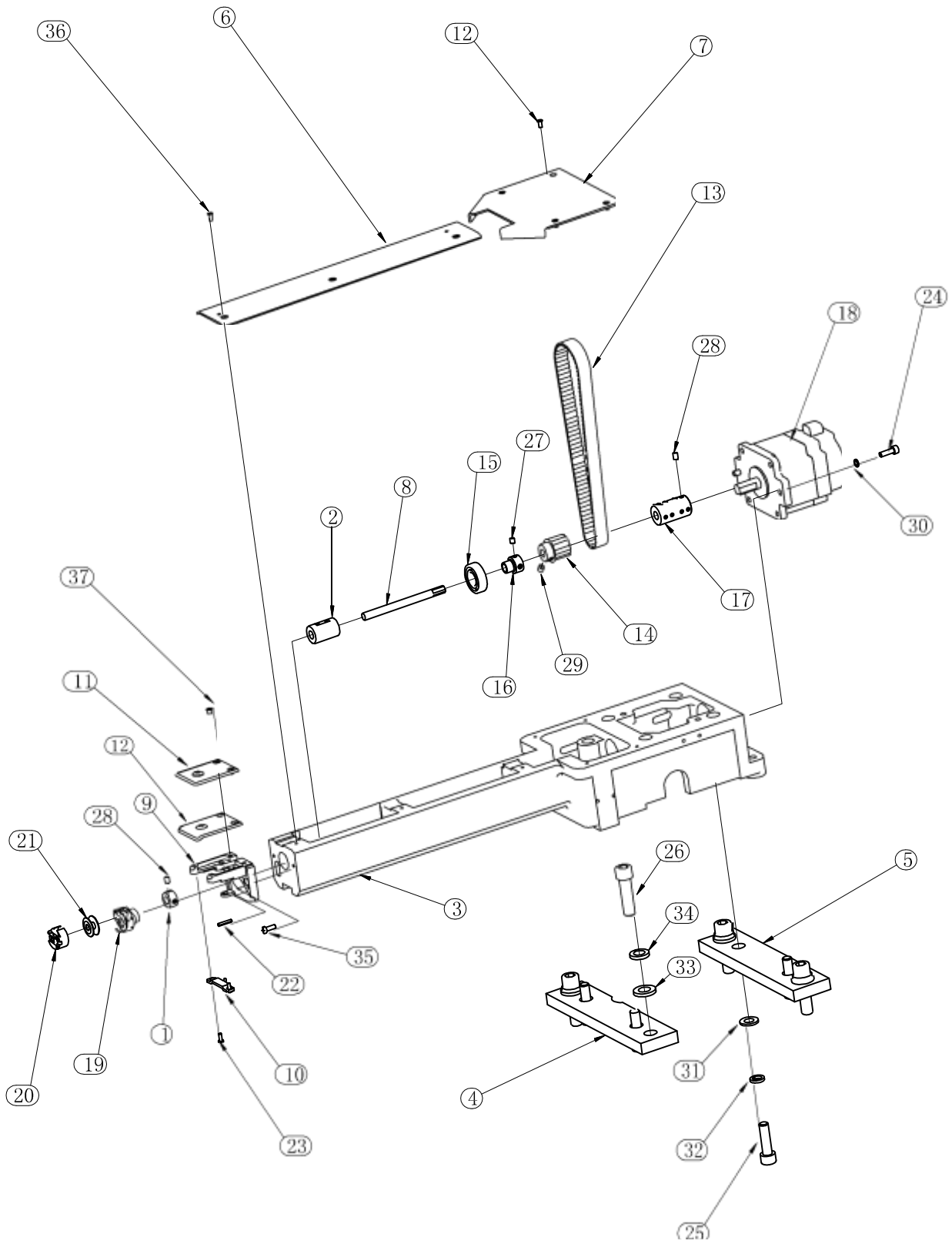

Table Top

Parts of the table, chassis and bed. Reference picture on previous page.

NO	Part #	Part Name	Remark
1	03010103	base	
2	03010201	cover front R	
3	03010202	cover front L	
4	03010203	cover rear R	
5	03010204	cover rear L	
6	03010210	cover bracket	
7	03010211	connecting plate	
8	03010212	cover bracket cover	
9	03010213	bracket cover	
10	03010214	bracket	
11	03010301	flatbed embroidery table	
12	03010302	support board	
13	03010303	table support base	
14	03010304	table cushion	
15	03010305	table back block	
16	03010309	cushion felt	
17	80270821	adjustment support arm	
18	80700205	4x16 screw	
19	80700206	4x16 screw	
20	80700302	3x12 screw	
21	80746406	M4x6 screw	
22	80746408	4x8 screw M3x8	
23	80813308	screw	
24	80860410	M4x10screw	



Rotary Hook Base

Rotary Hook Base. Reference picture on previous page

NO	Part #	Part Name	Remark
1	02101121	baffle	
2	02101131	bearing collar	
3	03021101	rotary hook base front	
4	03021102	bracket	
5	03021103	rear bracket	
6	03021105	cover	
7	03021106	back cover lower	
8	03021107	shaft	
9	03021301	needle plate base rotary	
10	03021321	position hook	
11	03021381	needle plate	
12	03021382	bent needle plate	
13	80025506	timing belt	
14	80025602	timing pulley	
15	80031524	bearing	
16	80037901	bearing collar	
17	80037912	bearing collar	
18	80310701	servo motor	
19	80620291	rotary hook	
20	80620301	bobbin case	
21	80620302	bobbin	
22	80685135	3x16 spring pin	
23	80740308	M3x8 screw	
24	80810516	M5x16 screw	
25	80811035	M10x35 screw	
26	80811245	M12x45 screw	
27	80880506	M5x6 screw	
28	80880508	M5x8 screw	
29	80880608	M6x8 screw	
30	80900513	M5 spring spacer	
31	80901002	M10 spacer	
32	80901013	M10 spring spacer	
33	80901202	M12 plain spacer	
34	80901213	M12 spring spacer	
35	80924114	11/64x12 screw	
36	80924122	9/64x8 screw	
37	80924131	11/64x6 screw	

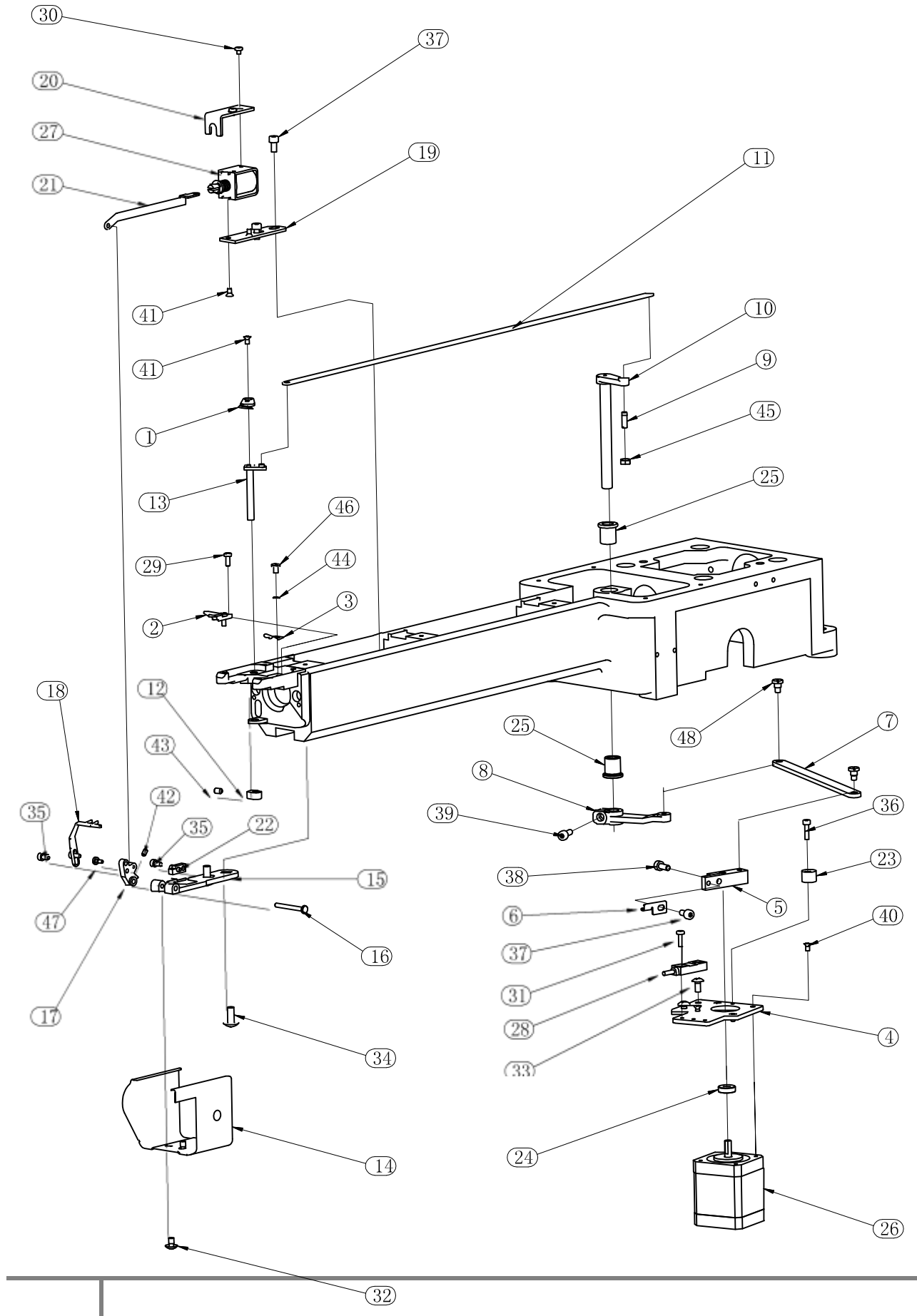

Trimmers

Trimmers. Reference picture on previous page

NO	Part #	Part Name	Remark
1	02101231	trimming drive arm	
2	02101232	movable knife	
3	02101233	fixed knife	
4	03021201	fixed knife shrapnel	
5	03021202	trimming drive block	
6	03021203	trimming induction block	
7	03021204	trimming connecting rod	
8	03021211	trimming drive rod	
9	03021212	trimming drive arm pin	
10	03021220	trimming drive arm	
11	03021221	trimming pull rod	
12	03021232	movable knife drive arm clipper	
13	03021242	movable knife drive arm	
14	03021311	needle plate base cover	
15	03021501	picker bracket	
16	03021502	picker fork connecting pin	
17	03021503	picker fork base	
18	03021504	picker fork	
19	03021511	picker solenoid installation plate	
20	03021512	picker solenoid limit plate	
21	03021513	picker connecting rod	
22	03021524	picker stopper	
23	03040605	silencing block	
24	80030540	nylon cushion	
25	80030803	face bearing	
26	80304203	trimming motor	
27	80320204	picker solenoid	
28	80333601	micro approach switch	
29	80740308	M3x8 screw	
30	80744303	M3x3 screw	
31	80744310	M3x10 screw	
32	80746406	M4x6 screw	
33	80746408	M4x8 screw	
34	80746512	M5x12 screw	
35	80810306	M3x6 screw	
36	80810312	M3x12 screw	
37	80810408	M4x8 screw	
38	80810410	M4x10 screw	
39	80810412	M4x12 screw	
40	80860306	M3x6 screw	
41	80860324	M3x4 screw	
42	80880306	M3x6 screw	
43	80880406	M4x6 screw	
44	80900318	M3 spring spacer	
45	80900421	M4 nut	

46	80924150	9/64x5 screw	
47	80924201	M2.5x4-3x2 screw	
48	80924211	M4x4-5x3.5 screw	

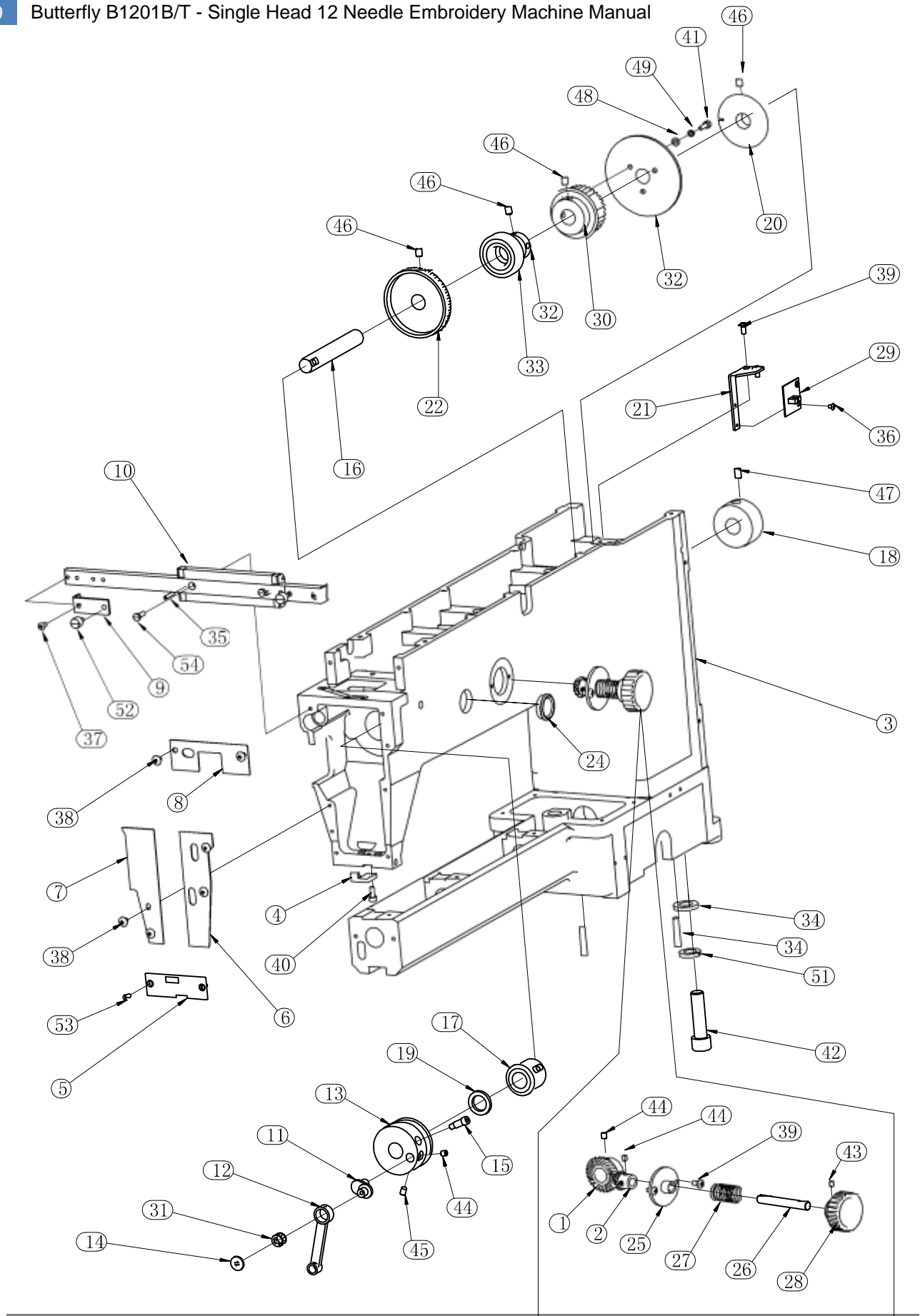

Arm

Arm. Reference picture on previous page

NO	Part #	Part Name	Remark
1	01030131	bevel gear big	
2	01030132	bevel gear small	
3	03040101	arm	
4	03040121	positioning plate	
5	03040123	lower front cover	
6	03040124	front cover R	
7	03040125	front cover L front	
8	03040126	cover Up guide	
9	03040180	rail baffle straight	
10	03040184	guide rail	
11	03040201	eccentric pin	
12	03040202	drive connecting rod	
13	03040203	arm cam	
14	03040204	drive connecting rod screw	
15	03040205	cam pin	
16	03041201	upper shaft	
17	03041202	upper shaft front bushing	
18	03041203	upper shaft rear bushing	
19	03041204	cam cushion	
20	03041207	zero position detection disk	
21	03041208	zero position coupler bracket	
22	03041211	main shaft dial	
23	03041222	arm shaft pulley baffle	
24	03041281	dial observer	
25	03041301	handle bushing	
26	03041302	handle shaft	
27	03041303	handle spring	
28	03041304	adjustment handle	
29	03160702	zero position detection plate	
30	80025601	timing pulley	
31	80030831	bearing	
32	80031502	bearing collar	
33	80032022	bearing	
34	80682101	6x30 pin	
35	80685135	3x16 pin	
36	80742304	M3x4 screw	
37	80744406	M4x6 screw	
38	80746406	M4x6 screw	
39	80746408	M4x8 screw	
40	80810410	M4x10 screw	
41	80810412	M4x12 screw	
42	80811245	M12x45 screw	
43	80880406	M4x6 screw	
44	80880506	M5x6 screw	
45	80880508	M5x8 screw	

46	80880608	M6x8 screw	
47	80880610	M6x10 screw	
48	80900408	M4 plain washer	
49	80900413	M4 spring washer	
50	80901202	M12 spacer	
51	80901213	M12 spring spacer	
52	80920403	M4x8 screw	
53	80924122	9/64x8 screw	
54	80924144	M4x12 screw	

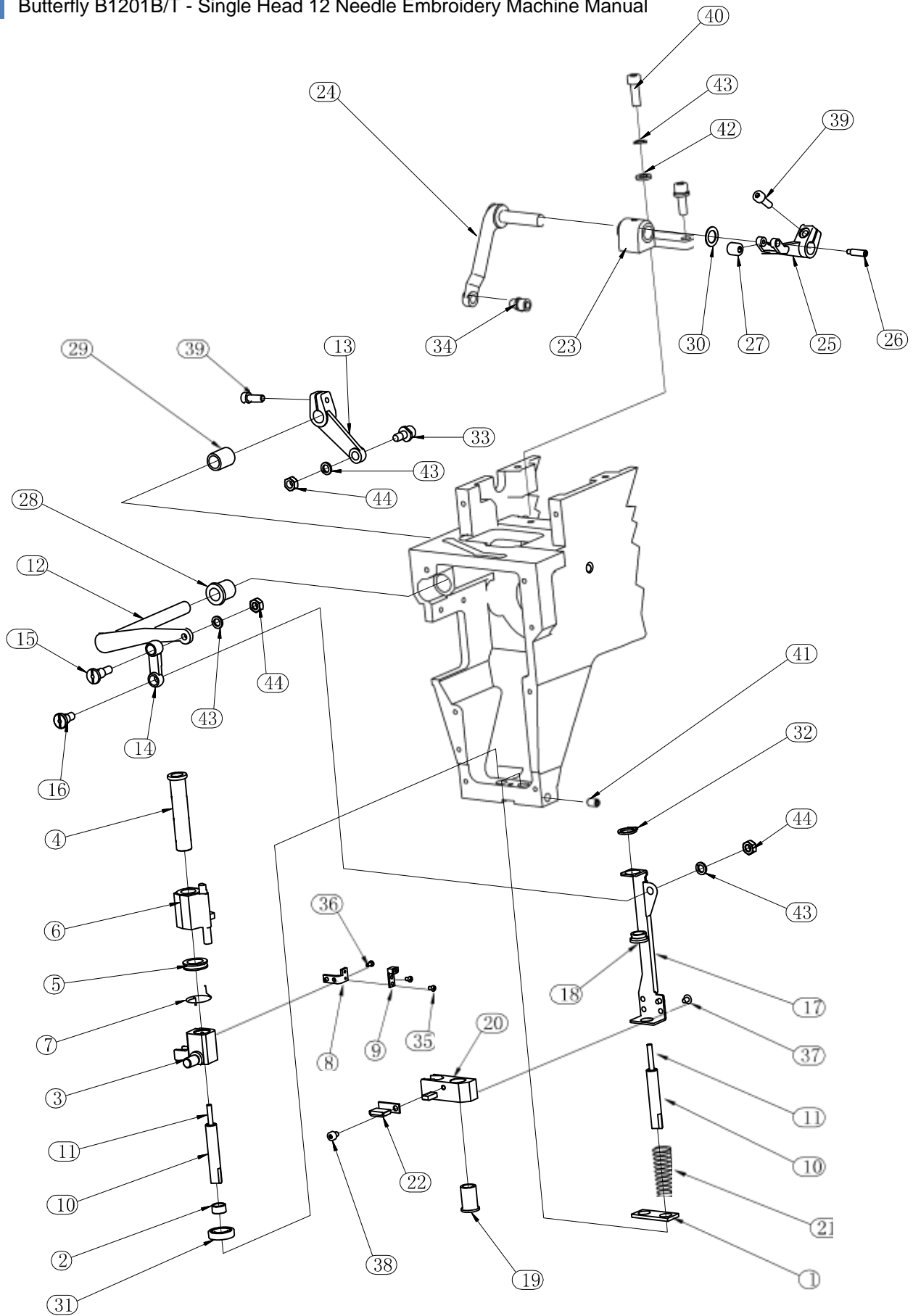

Needle Bar Driver

Needle bar Driver. Reference picture on previous page

NO	Part #	Part Name	Remark
1	03040111	oil fencing felt	
2	03040122	drive shaft collar	
3	03040301	needle bar drive block	
4	03040302	shaft bushing	
5	03040304	torsion spring positioning block	
6	03040305	drive block	
7	03040306	driver returning spring	
8	03040321	silencing base support	
9	03040322	drive block support	
10	03040351	arm drive shaft	
11	03040352	wick	
12	03040401	presser foot drive connecting shaft	
13	03040402	presser foot cam guide rod	
14	03040403	presser foot connecting rod	
15	03040411	connecting rod pin-up	
16	03040412	connecting rod pin-lower	
17	03040421	presser foot slide bracket	
18	03040422	shaft bushing A	
19	03040423	shaft bushing B	
20	03040424	presser foot drive block	
21	03040425	presser foot guide spring	
22	03040426	presser foot buffer cushion	
23	03041101	take-up bar base	
24	03041102	take-up connecting rod-main	
25	03041181	take-up connecting rod	
26	03041183	take-up connecting lever pin	
27	80030431	bearing	
28	80030803	face bushing	
29	80030811	straight bushing	
30	80030851	steel washer	
31	80030902	bearing	
32	80031072	elastic collar	
33	80260801	roller pin	
34	80260802	wheel roller pin	
35	80740203	M2x3 screw	
36	80740204	M2x4 screw	
37	80742304	M3x4 screw	
38	80810304	M3x4 screw	
39	80810412	M4x12 screw	
40	80810516	M5x16 screw	
41	80880508	M5x8 screw	
42	80900502	M5 spacer	
43	80900513	M5 spring spacer	
44	80900521	M5 nut	

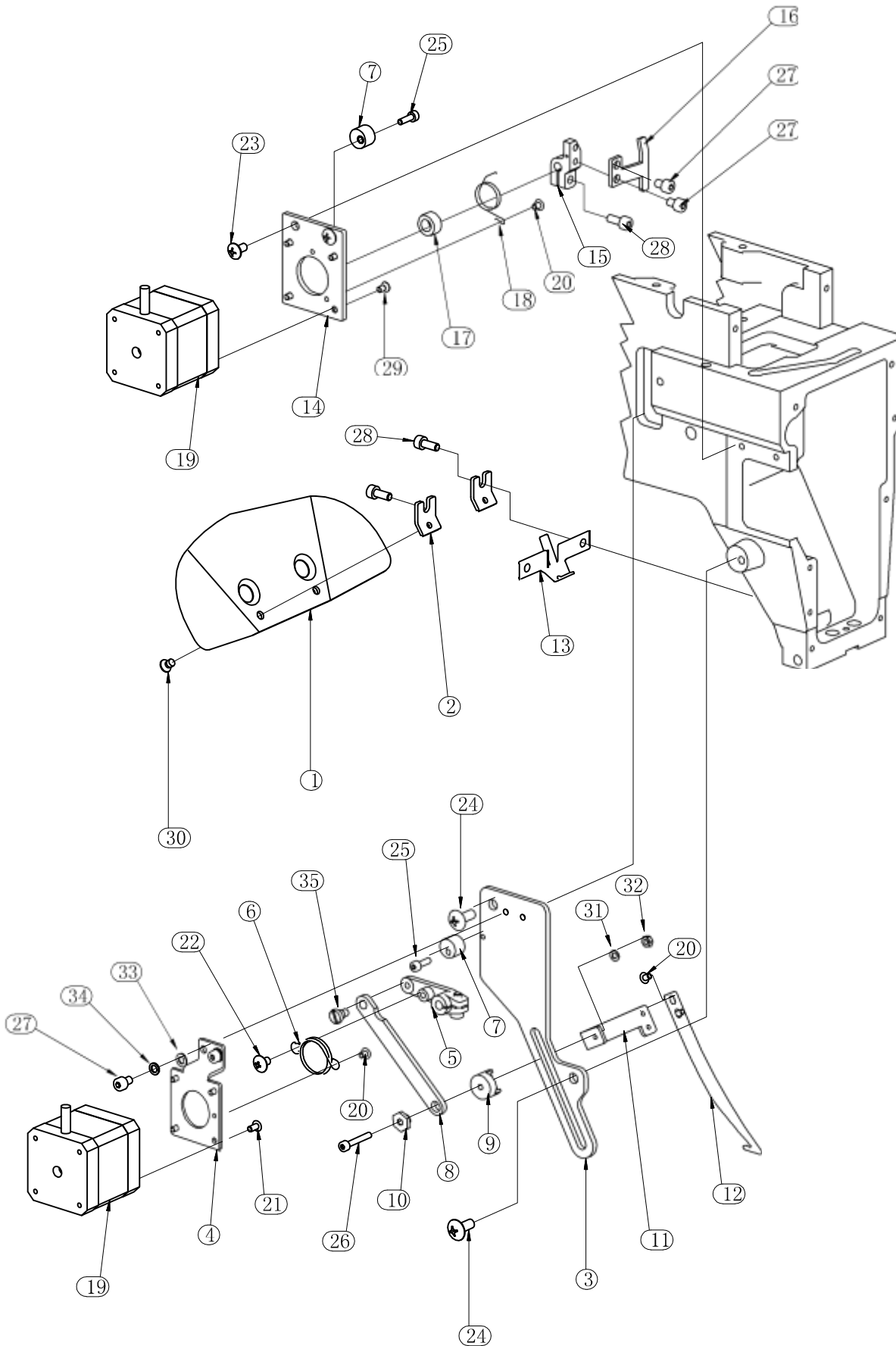

Upper Thread Hook

Upper Thread Hook. Reference picture on previous page

NO	Part #	Part Name	Remark
1	03040151	baffle-lower	
2	03040154	baffle bracket-lower	
3	03040601	thread hook plate hook	
4	03040602	motor base hook drive	
5	03040603	arm	
6	03040604	drive arm returning spring	
7	03040605	silencing block	
8	03040606	thread hook connecting bar	
9	03040607	thread hook positioning block	
10	03040608	hexagon ring	
11	03040610	thread hook connecting block	
12	03040611	thread hook	
13	03040631	hook guide	
14	03040701	arm motor plate arm	
15	03040702	jumping plate	
16	03040703	jumping lever bracket	
17	03040704	plastic washer	
18	03040705	jumping torsion spring	
19	80304201	stepping motor	
20	80742304	M3x4 screw	
21	80742306	M3x6 screw	
22	80746406	M4x6 screw	
23	80746408	M4x8 screw	
24	80746512	M5x12 screw	
25	80810310	M3x10 screw	
26	80810320	M3x20 screw	
27	80810406	M4x6 screw	
28	80810410	M4x10 screw	
29	80860306	M3x6 screw	
30	80860406	M4x6 screw	
31	80900301	M3 plain cushion	
32	80900321	M3 plain nut	
33	80900402	M4 cushion	
34	80900413	M4 spring cushion	
35	80924211	M4x4-5x3.5 screw	

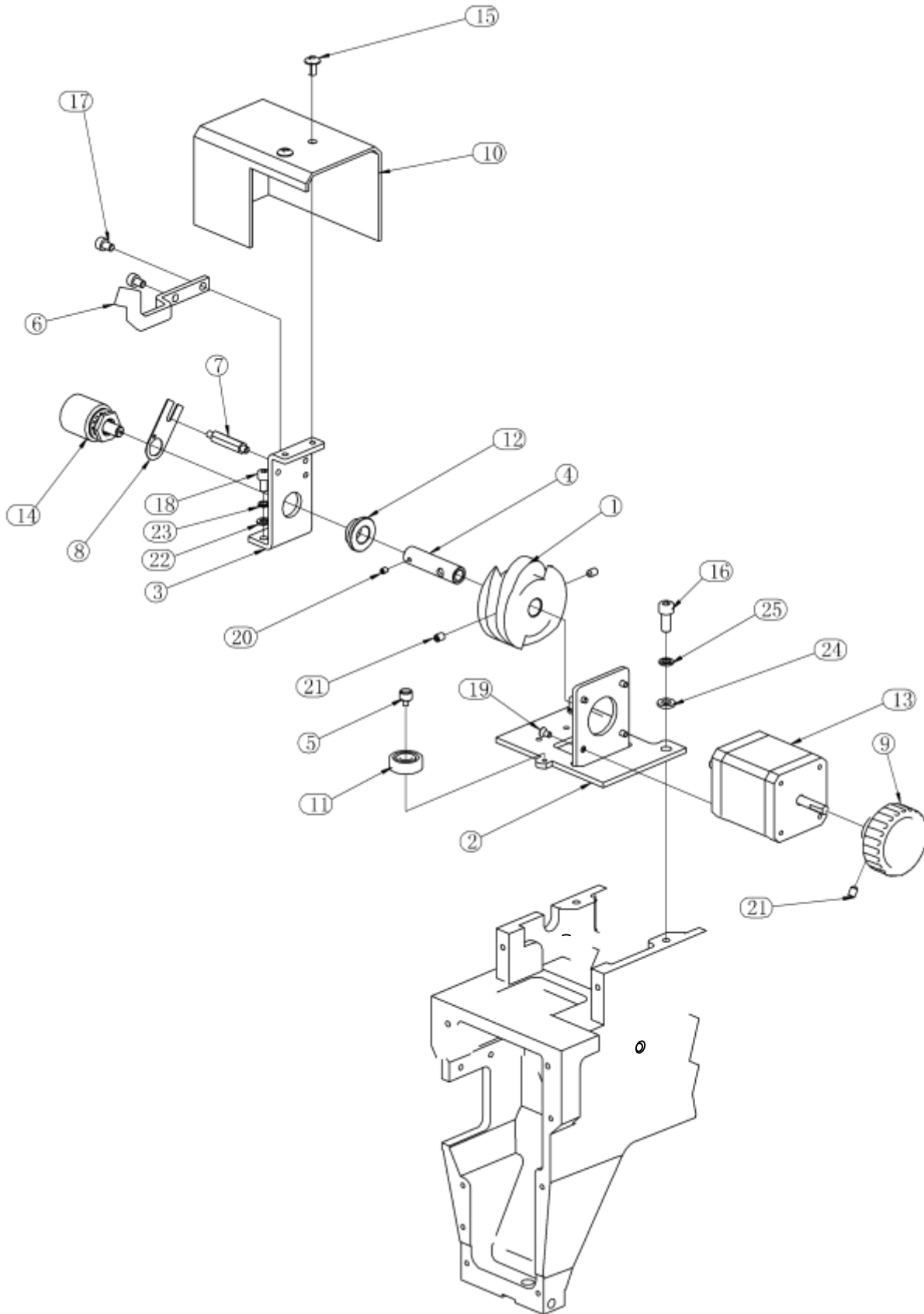

Color Change System

Color Change System. Reference picture on previous page

NO	Part #	Part Name	Remark
1	01293105	color change cam	
2	03040503	color change	
3	03040504	base motor	
4	03040506	support	
5	03040507	color change bushing	
6	03040508	breakage detection base plate	
7	03040509	potentiometer fixed bolt	
8	03040510	potentiometer support	
9	03040511	color change handle	
10	03040512	change cover	
11	80030722	bearing	
12	80031003	step bearing	
13	80304212	stepping motor	
14	80333702	potentiometer	
15	80746408	M4x8 screw	
16	80810512	M5x12 screw	
17	80813406	M4x6 screw	
18	80813408	M4x8 screw	
19	80860306	M3x6 screw	
20	80880304	M3x4 screw	
21	80880406	M4x6 screw	
22	80900402	M4 cushion	
23	80900418	M4 spring cushion	
24	80900502	M5 cushion	
25	80900513	M5 spring cushion	

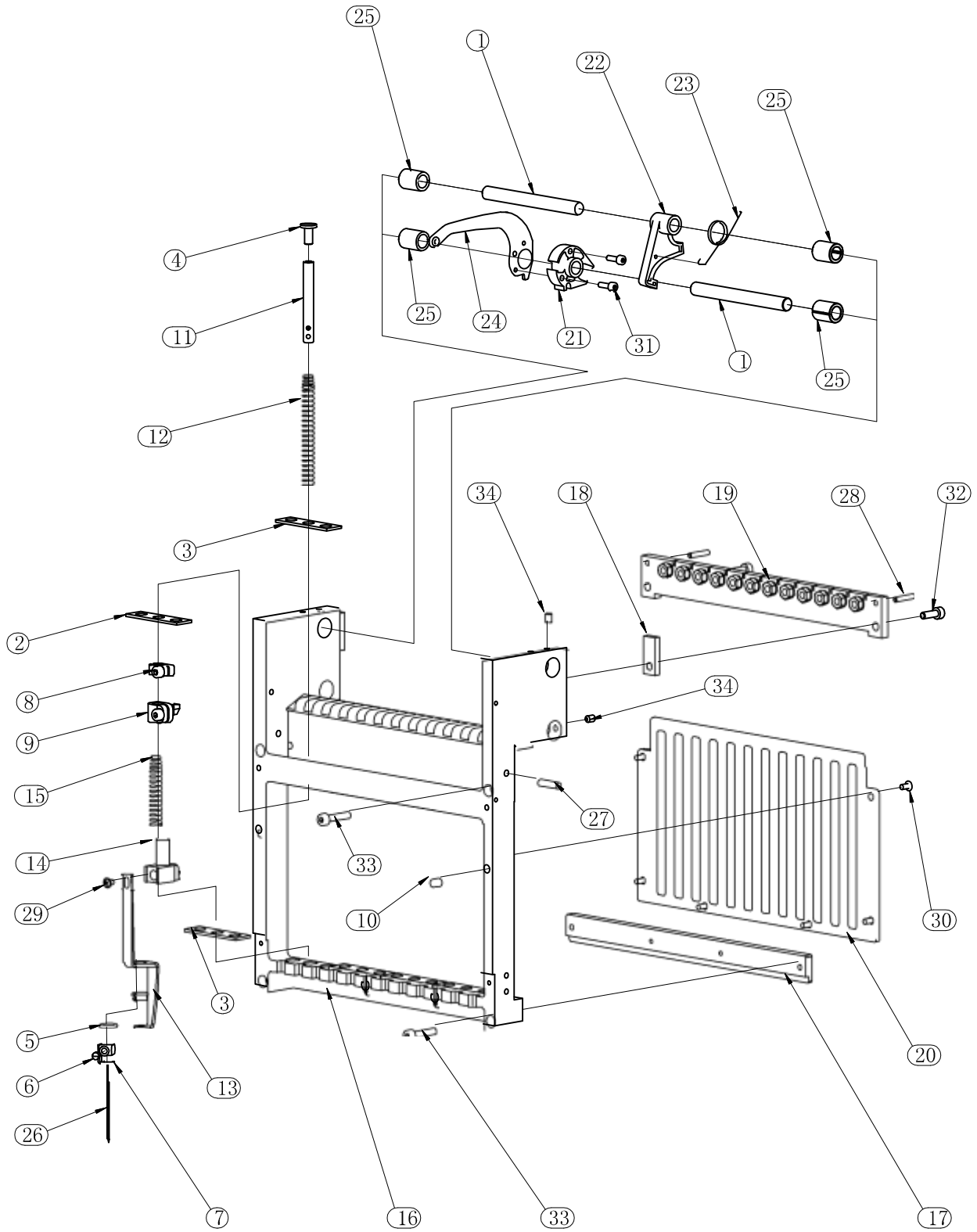

Needle Case A

Needle Case A. Reference picture on previous page

N	Part #	Part Name	Remark
1	01221532	take-up lever shaft	
2	01221605	rubber cushion felt	
3	01221606	packing needle bar	
4	01222102	screw baffle ring	
5	01222109		
6	01222183	needle clamp screw	
7	01222184	needle clamp	
8	01222192	upper dead point clamp	
9	01222193	needle bar connecting pin	
1	01227102	magnet	
11	03080101	needle bar	
12	03080102	needle bar spring	
13	03080103	presser foot	
14	03080104	presser foot bushing	
15	03080108	presser foot spring	
16	03081112	needle case	
17	03081121	lower guide rail	
18	03081202	cushion	
19	03081293	color change plate	
20	03081301	needle bar guide	
21	03081501	take-up lever plastic block	
22	03081502	take-up lever positioning block	
23	03081503	positioning block torsion spring	
24	03081504	take-up lever	
25	03081505	take-up shaft block	
26	80621101	needle	
27	80681101	pin	
28	80685135	3x16 screw	
29	80742304	M3x4 screw	
30	80746306	M3x6 screw	
31	80810310	M3x10 screw	
32	80810412	M4x12 screw	
33	80810420	M4x20 screw	
34	80880406	M4x6 screw	

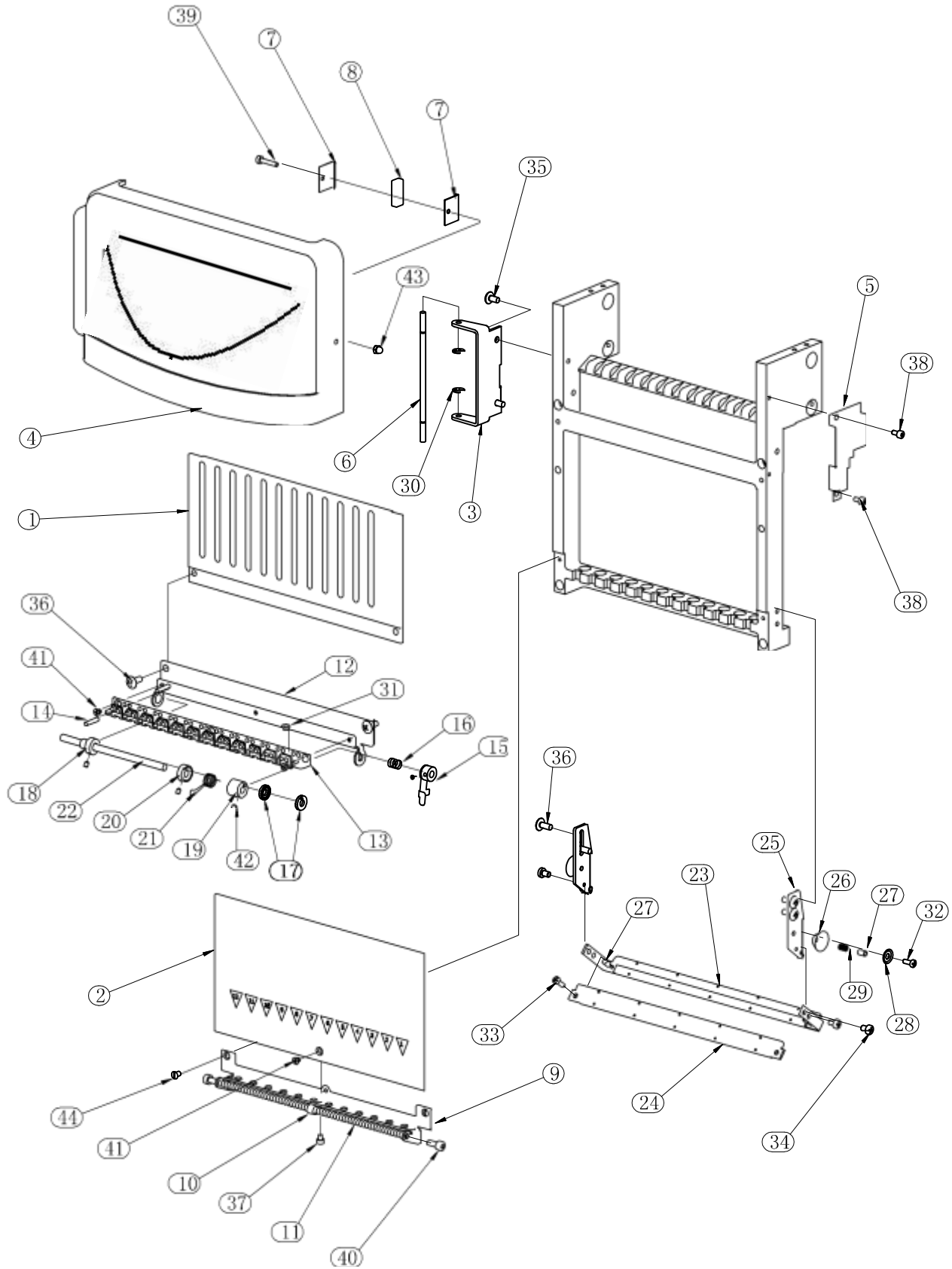

Needle Case B

Needle Case B. Reference picture on previous page

NO	Part #	Part Name	Remark
1	03081302	upper face plate	
2	03081303	front face plate	
3	03082301	cover support	
4	03082302	plastic front cover	
5	03082303	magnet base	
6	03082304	connecting shaft	
7	03082305	magnet clamp	
8	03082306	magnet	
9	03082501	lower thread course	
10	03082503	spring bracket	
11	03082502	lower thread spring	
12	03082511	middle thread course base	
13	03082512	roller stand	
14	03082513	middle thread course pin	
15	03082523	tension wrench	
16	03082524	spring	
17	03082525	bevel cushion	
18	03082526	shaft collar	
19	03082527	take-up spring collar	
20	03082528	take-up spring baffle	
21	03082530	take-up spring	
22	03082531	middle thread course shaft	
23	03086101	face thread clamp base	
24	03086102	face thread clamp plate	
25	03086103	face thread clamp bracket	
26	03086123	thread suspender disk	
27	03086124	thread suspender baffle	
28	03086125	thread suspender spring presser	
29	03086131	thread suspender spring	
30	80030471	E-ring	
31	80628133	porcelain bushing	
32	80740308	M3x8 screw	
33	80030310	M3x10 screw	
34	80740406	M4x6 screw	
35	80746408	M4x8 screw	
36	80746410	M4x10 screw	
37	80813304	M3x4 screw	
38	80813306	M3x6 screw	
39	80813316	M3x16 screw	
40	80813410	M4x10 screw	
41	80860304	M3x4 screw	
42	80880304	M3x4 screw	
43	80900331	M3 nut	
44	80924121	9/64x6 screw	

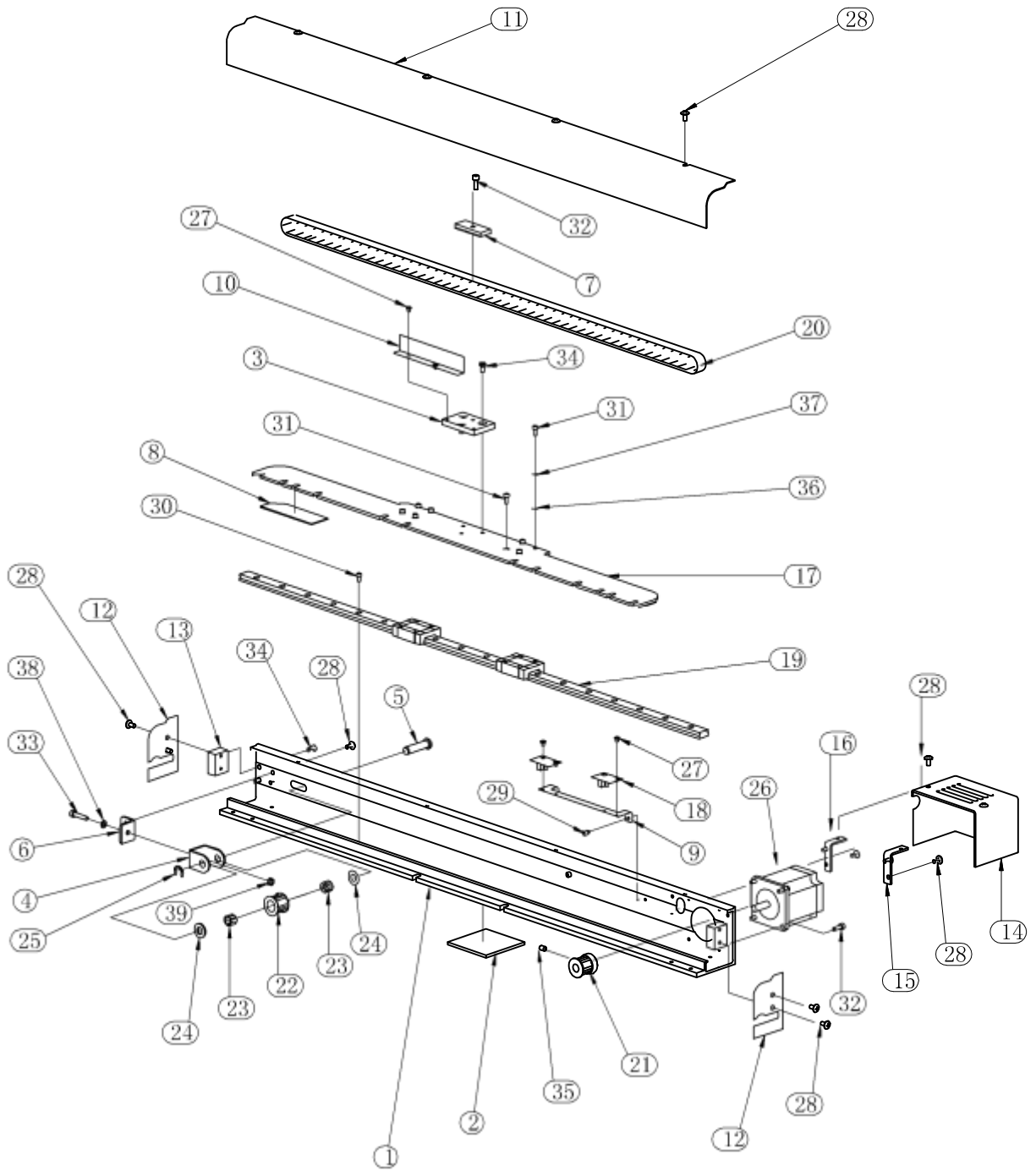

X-Axis Drive System

X-Axis Drive System. Reference picture on previous page

NO	Part #	Part Name	Remark
1	03100101	drive shaft	
2	03100102	frame felt	
3	03100104	connecting plate press block	
4	03100105	timing pulley bracket	
5	03100106	timing pulley shaft	
6	03100107	tension support	
7	03100108	belt press plate	
8	03100109	connecting plate frame felt	
9	03100110	limit installation support limit	
10	03100112	buffer	
11	03100116	cover	
12	03100117	side cover	
13	03100118	side cover support	
14	03100121	motor cover	
15	03100122	motor cover bracket-L	
16	03100123	motor cover bracket-R	
17	03100131	X drive connecting plate	
18	03160701	limit plate	
19	80010115	standard guide	
20	80023521	timing belt	
21	80023601	timing pulley A	
22	80023602	timing pulley B	
23	80030831	roller bearing	
24	80030861	nylon spacer	
25	80030871	E-ring	
26	80305752	stepping motor	
27	80742304	M3x4 screw	
28	80746408	M4x8 screw	
29	80810304	M3x4 screw	
30	80810306	M3x6 screw	
31	80810308	M3x8 screw	
32	80810412	M4x12 screw	
33	80810420	M4x20 screw	
34	80860410	M4x10 screw	
35	80880508	M5x8 screw	
36	80900302	M3 plain cushion	
37	80900313	M3 spring cushion	
38	80900401	M4 plain cushion	
39	80900421	M4 nut	

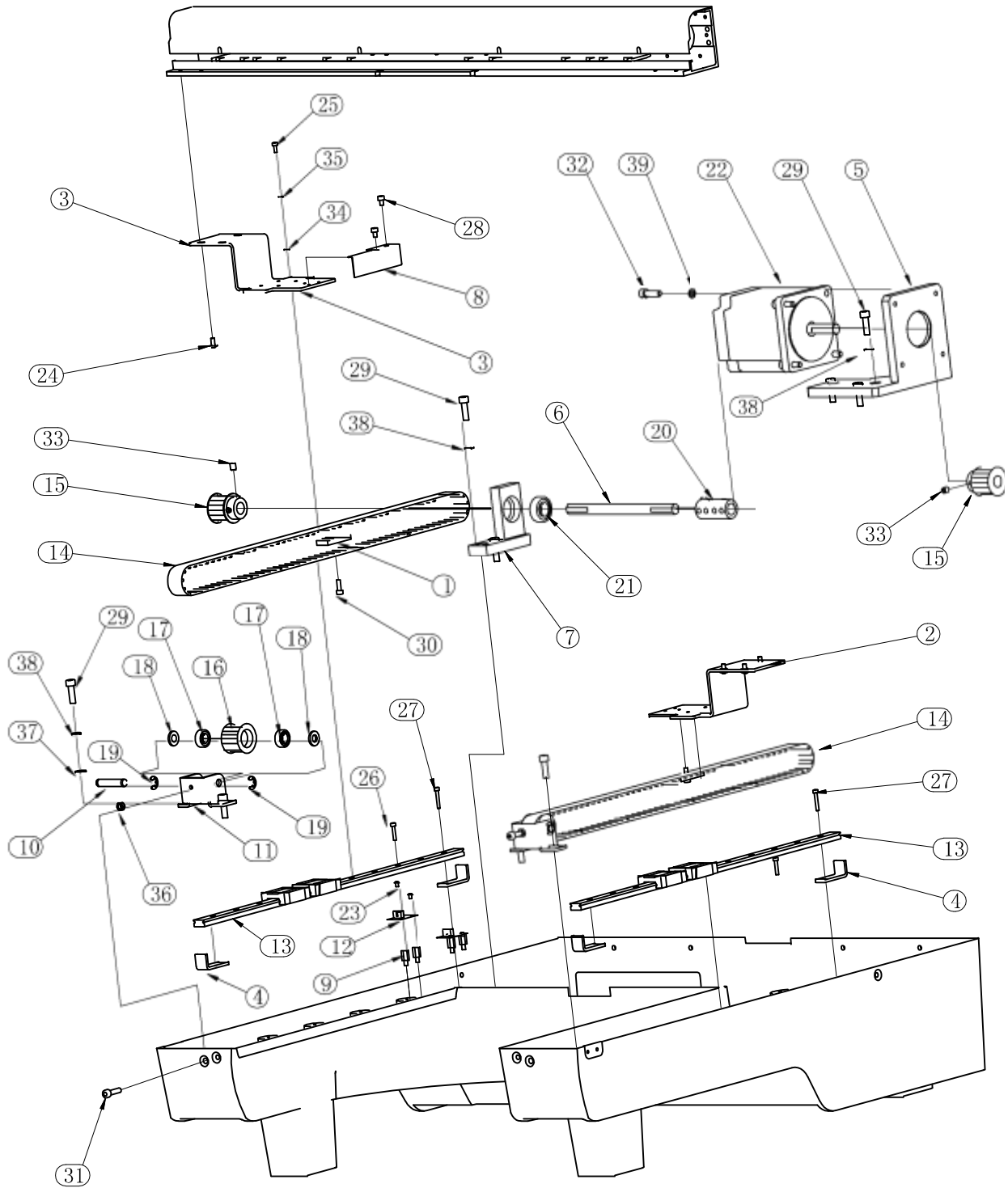

Y-Axis Drive System

Y-Axis Drive System. Reference picture on previous page

NO	Part #	Part Name	Remark
1	03100108	belt press plate	
2	03105101	drive connecting plate-R	
3	03105102	X drive connecting plate-L	
4	03105103	guide buffer	
5	03105111	motor base	
6	03105112	drive shaft	
7	03105114	bearing base	
8	03105115	limit buffer	
9	03105116	limit optical coupler base	
10	03105132	pulley shaft	
11	03105133	tension base	
12	03160701	limit plate	
13	80015116	guide rail	
14	80023522	timing belt	
15	80023615	timing pulley A	
16	80023616	timing pulley B	
17	80030822	roller bearing	
18	80030861	nylon washer	
19	80030871	E-ring	
20	80031211	shaft cushion	
21	80031223	bearing	
22	80308653	stepping motor	
23	80742304	M3x4 screw	
24	80746408	M4x8 screw	
25	80810308	M3x8 screw	
26	80810316	M3x16 screw	
27	80810320	M3x20 screw	
28	80810406	M4x6 screw	
29	80810620	M6x20 screw	
30	80813412	M4x12 screw	
31	80813520	M5x20 screw	
32	80813620	M6x20 screw	
33	80880608	M6x8 screw	
34	80900302	M3 cushion	
35	80900313	M3 spring cushion	
36	80900521	M5 nut	
37	80900602	M6 cushion	
38	80900613	M6 spring washer	
39	80900618	M6 spring washer	

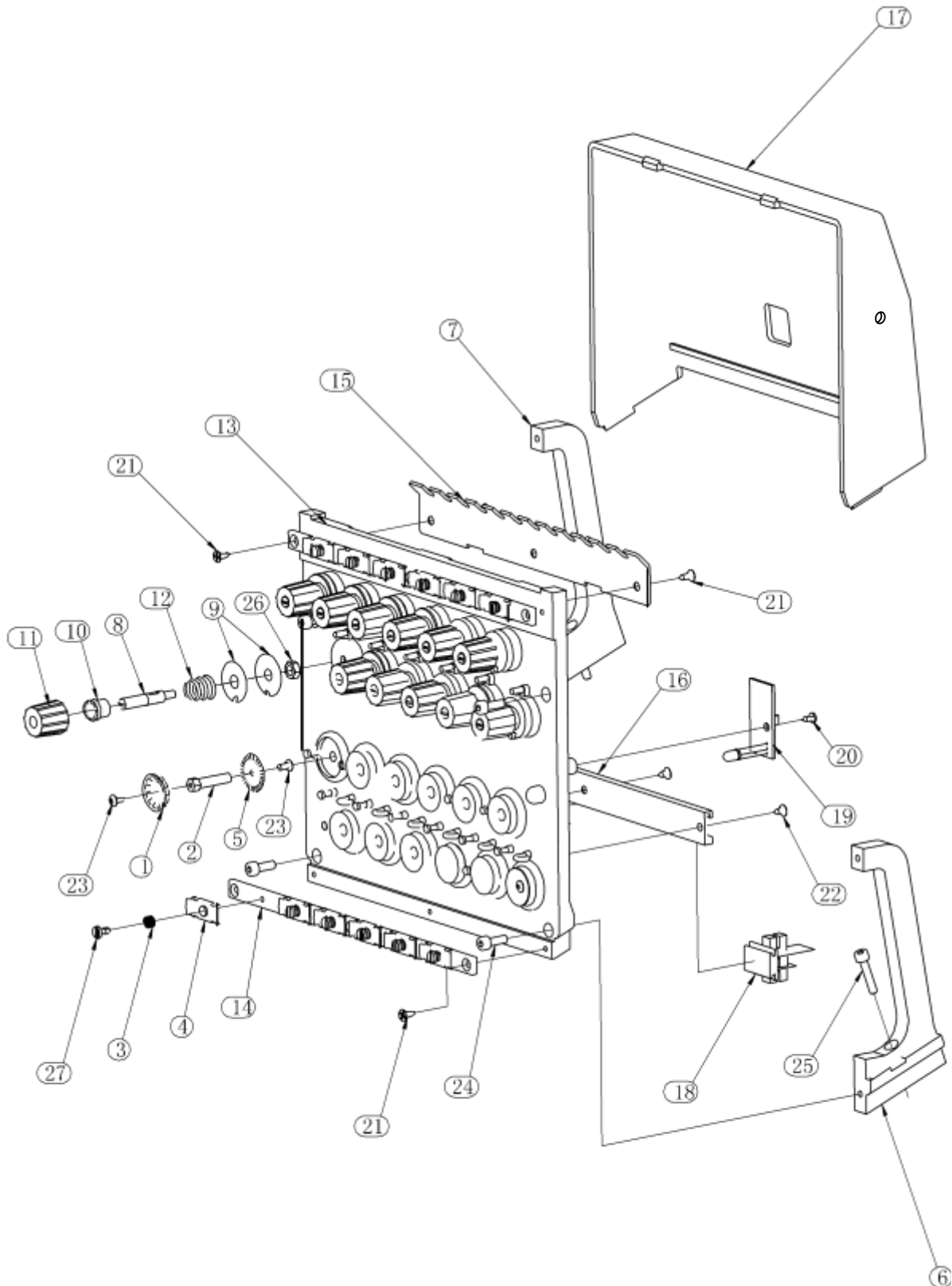

Tension Base

Tension Base. Reference picture on previous page

NO	Part #	Part Name	Remark
1	03130112	thread course wheel	
2	03130114	tension disk	
3	03130118	thread presser spring	
4	03130119	thread presser	
5	03130120	breakage detection disk	
6	03130131	support-L	
7	03130132	support-R	
8	03130141	thread tension screw	
9	03130142	thread tension disk	
10	03130143	adjust button	
11	03130144	small knob	
12	03130145	thread presser spring	
13	03131204	thread tension plate	
14	03131215	thread guide plate	
15	03131220	thread lead plate	
16	03131221	slider	
17	03131222	rear cover	
18	03160703	breakage detection plate	
19	03160801	alarm plate	
20	80700202	M3x6 screw	
21	80700301	3x8 screw	
22	80700306	3x6 screw	
23	80746306	M3x6 screw	
24	80813412	M4x12 screw	
25	80813420	M4x20 screw	
26	80900521	M5 nut	
27	80924203	M3x4-4x4 screw	

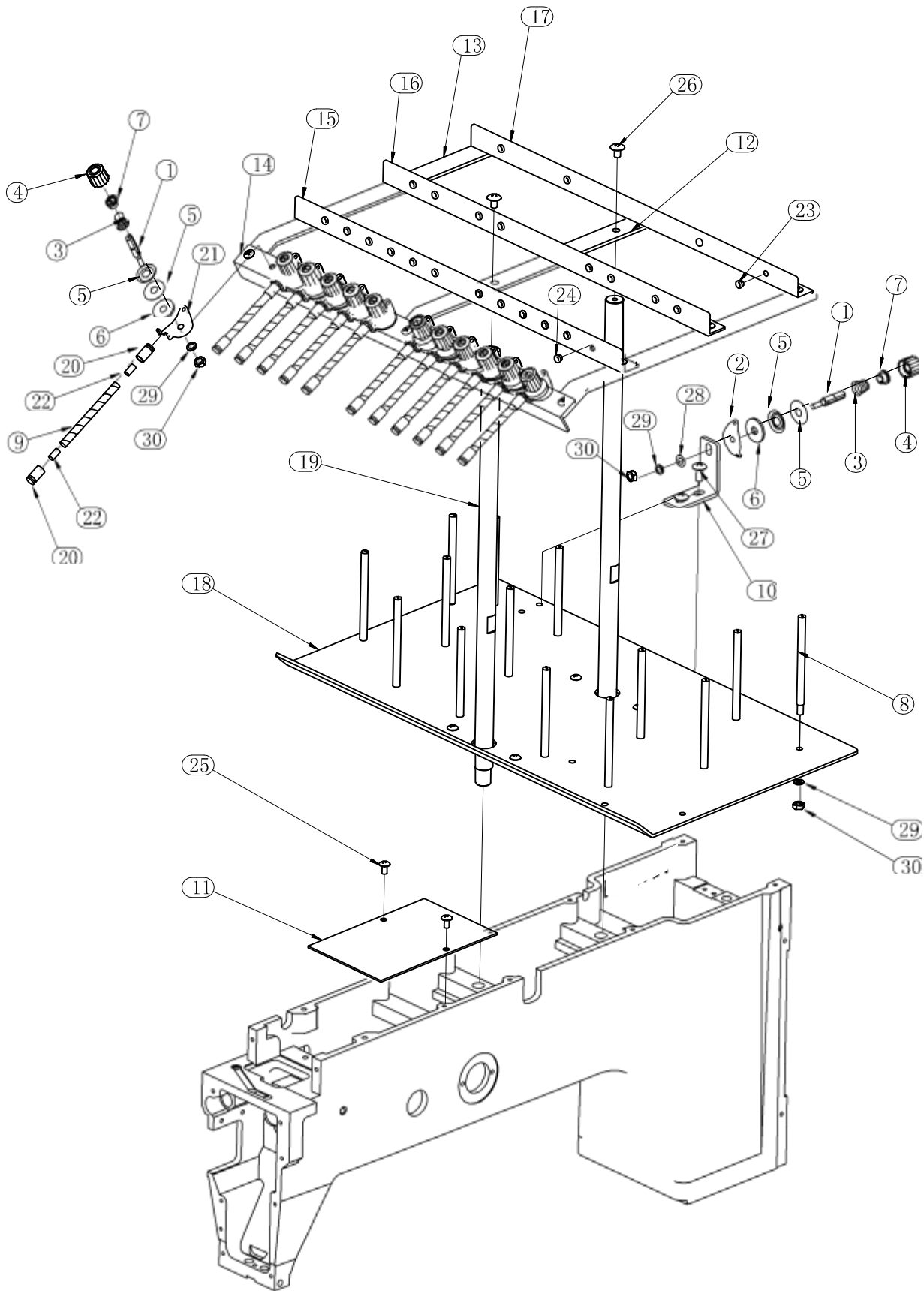

Thread Stand

Thread Stand. Reference picture on previous page

NO	Part #	Part Name	Remark
1	01901201	tension bolt	
2	01901202	thread lead	
3	01901203	plate tension	
4	01901204	spring tension	
5	01901205	regulator	
6	01901206	felt packing	
7	01901207	tension	
8	01902101	gasket coil	
9	01903123	bolt	
10	03010302	thread course	
11	03040127	upper cover	
12	03044101	support A	
13	03044102	support A	
14	03044103	thread stand	
15	03044104	A thread	
16	03044105	thread stand C	
17	03044106	thread stand D	
18	03044111	coil	
19	03044112	stand	
20	03044120	hose	
21	03044121	thread stand lead plate	
22	03044122	hose joint core	
23	80628131	white porcelain	
24	80628132	bushing red porcelain	
25	80746408	bushing M4x8 screw	
26	80746508	M5x8 screw	
27	80746512	M5x12 screw	
28	80900501	M5 plain washer	
29	80900513	M5 spring	
30	80900521	washer M5 nut	

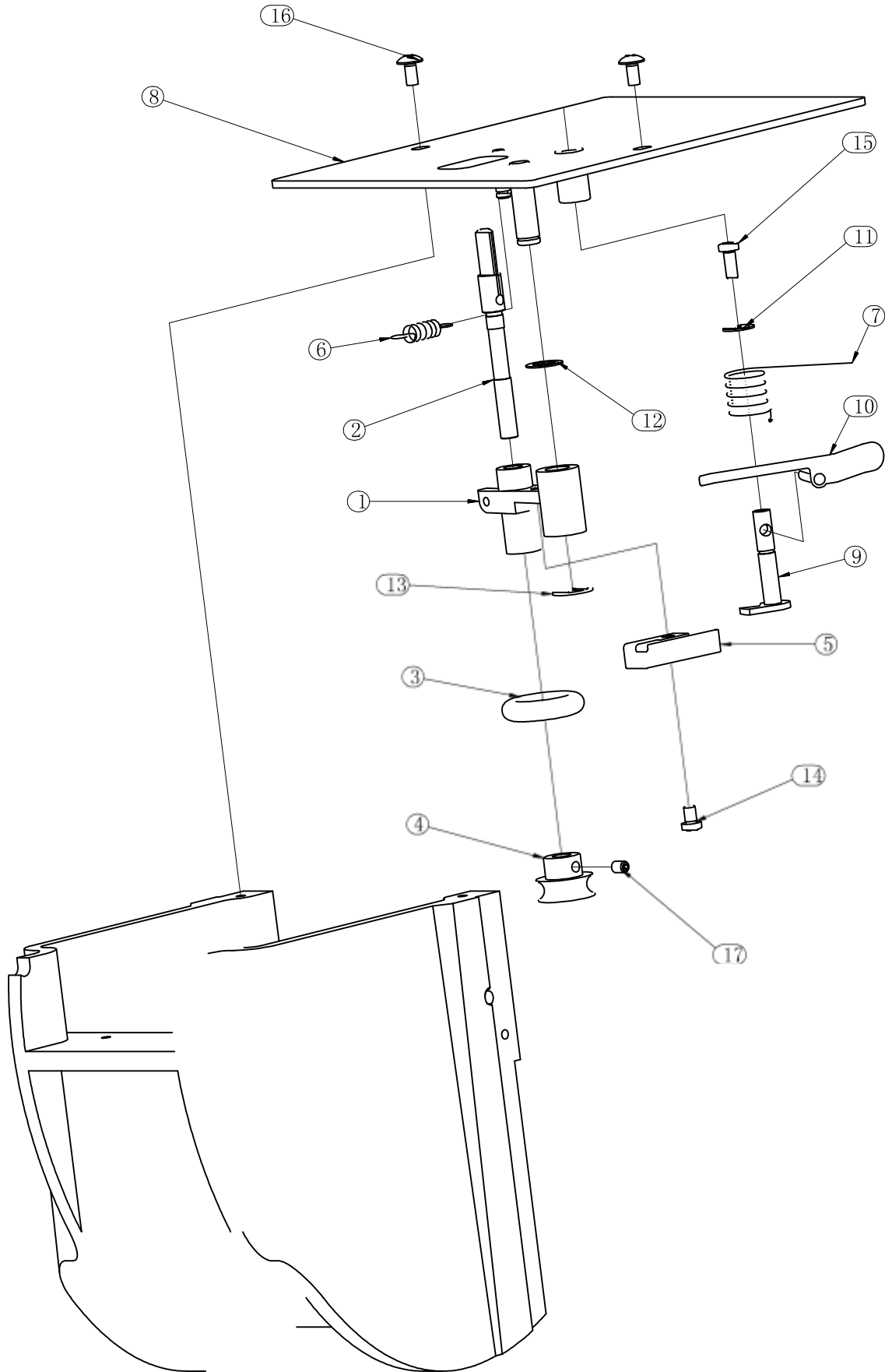

Bobbin Winder

Bobbin Winder. Reference picture on previous page

NO	Part #	Part Name	Remark
1	03041502	thread winder support arm	
2	03041503	thread	
3	03041504	winder shaft	
4	03041505	rubber roller	
5	03041506	roller	
6	03041517	support arm spring	
7	03041518	limit stand	
8	03041521	spring	
9	03041522	winder	
10	03041523	plate	
11	80030671	E-ring	
12	80030851	cushion	
13	80030871	E-ring	
14	80740406	M4x6 screw	
15	80740410	M4x10 screw	
16	80746408	M4x8 screw	
17	80880406	M4x6 screw	

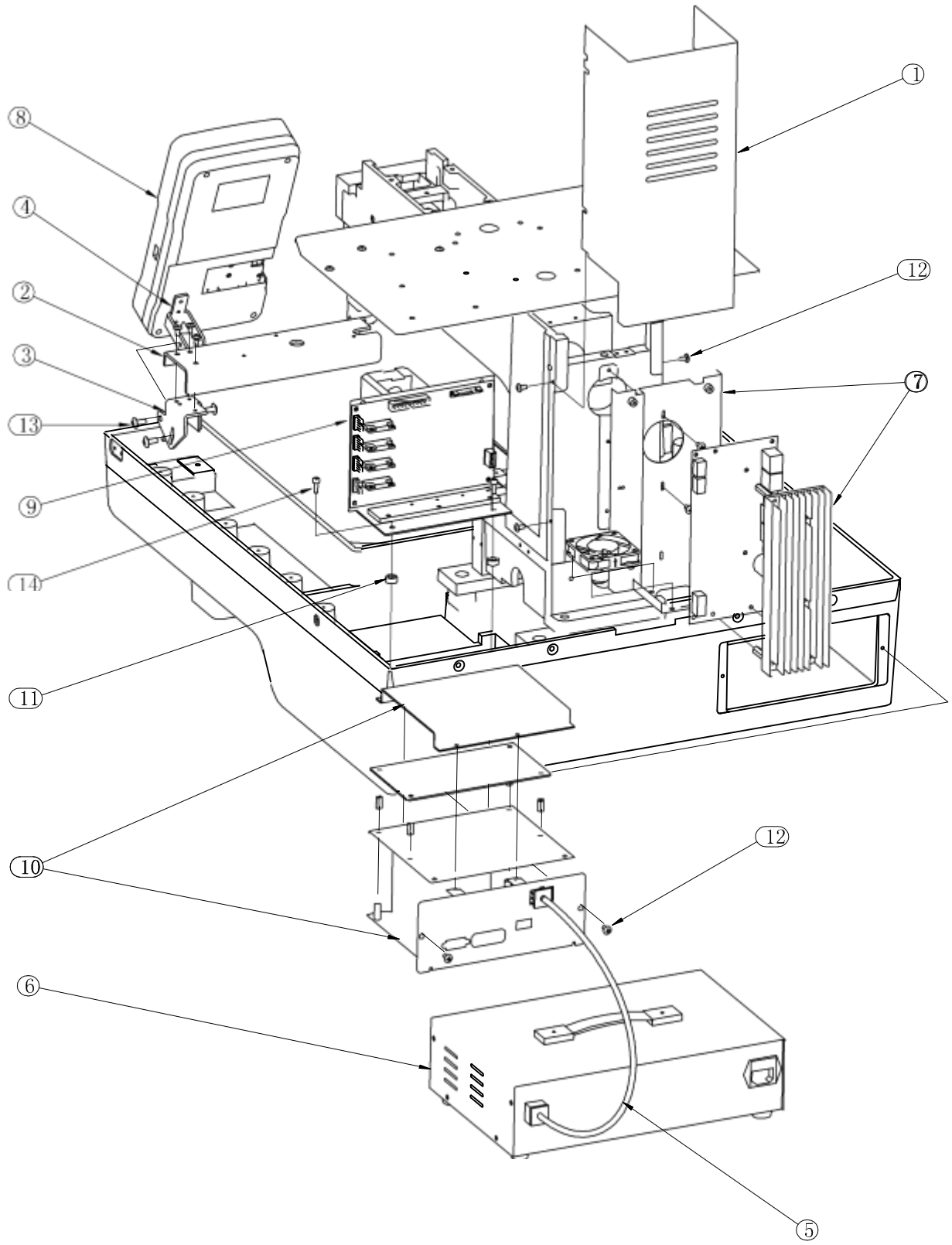

Electronics

Electronics. Reference picture on previous page

NO	Part #	Part Name	Remark
1	03040132	rear cover	
2	03044201	face plate bracket base face	
3	03044202	plate support base face	
4	03044203	plate stand	
5	03160101	power wire	
6	03160180	power box	
7	03160210	driver	
8	03160370	operation panel	
9	03160450	drive plate	
10	03160691	computer box	
11	80030642	nylon cushion	
12	80746408	M4x8 screw	
13	80746512	M5x12 screw	
14	80810412	M4x12 screw	

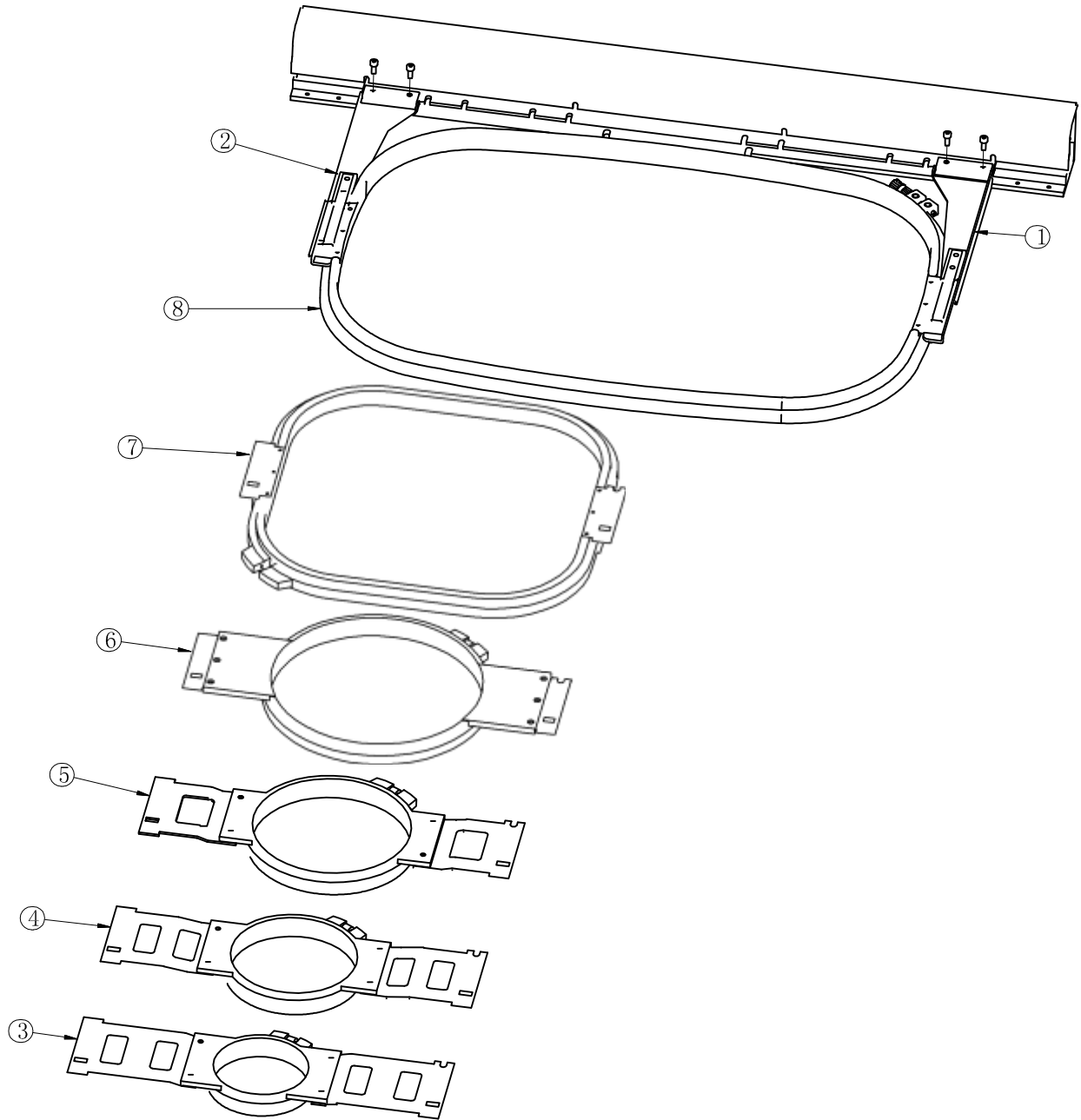

Hoops / Frames

Hoops / Frames. Reference picture on previous page

NO	Part #	Part Name	Remark
1	03100291	frame bracket-R	
2	03100292	frame bracket-L	
3	03171181	round frame-90	
4	03171681	round frame-120	
5	03172181	round frame-150	
6	03172681	round frame-200	
7	03173181	rectangle frame-290x290	
8	03173691	rectangle frame-540x360	
9	80813410	M4x10 screw	

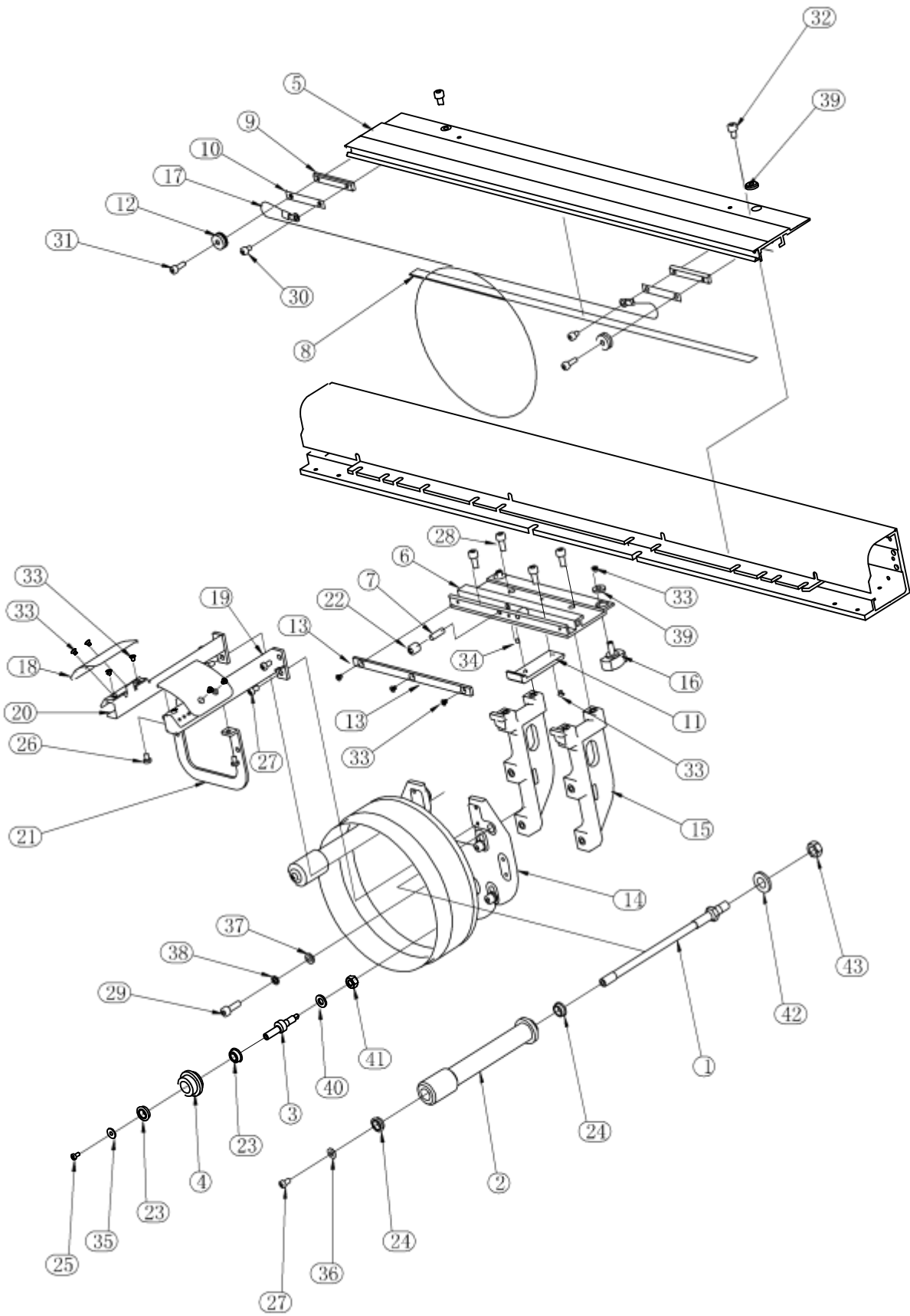

Cap Driver

Cap Driver. Reference picture on previous page

NO	Part #	Part Name	Remark
1	02810102	shaft A	
2	02810103	nylon rod	
3	02810105	pin shaft	
4	02810106	trolley	
5	02810301	cap frame support plate	
6	02810302	support bracket	
7	02810303	shaft B steel bar	
8	02810304	adjustment slider	
9	02810305	adjustment slider presser plate	
10	02810306		
11	02810307	plastic bracket plate	
12	02810308	nylon wheel	
13	02810309	plastic bar	
14	02810310	cap frame base	
15	02810313	cap frame main support	
16	02810313	screw	
17	02810351	steel wire	
18	02811203	support plate	
19	80030525	support-L	
20	80030525	support-R	
21	80030525	U stand	
22	80030525	roller bearing	
23	80030641	bearing	
24	80030842	bearing	
25	80740306	M3x6 screw	
26	80740406	M4x6 screw	
27	80740408	M4x8 screw	
28	80810512	M5x12 screw	
29	80810516	M5x16 screw	
30	80813406	M4x6 screw	
31	80813412	M4x12 screw	
32	80813508	M5x8 screw	
33	80860304	M3x4 screw	
34	80880304	M3x4 screw	
35	80900310	M3 plain washer	
36	80900405	M4 plain washer	
37	80900502	M5 plain washer	
38	80900513	M5 plain washer	
39	80900553	M5 screw cap	
40	80900602	M6 plain washer	
41	80900621	M6 nut	
42	80900802	M8 plain washer	
43	80900821	M8 nut	

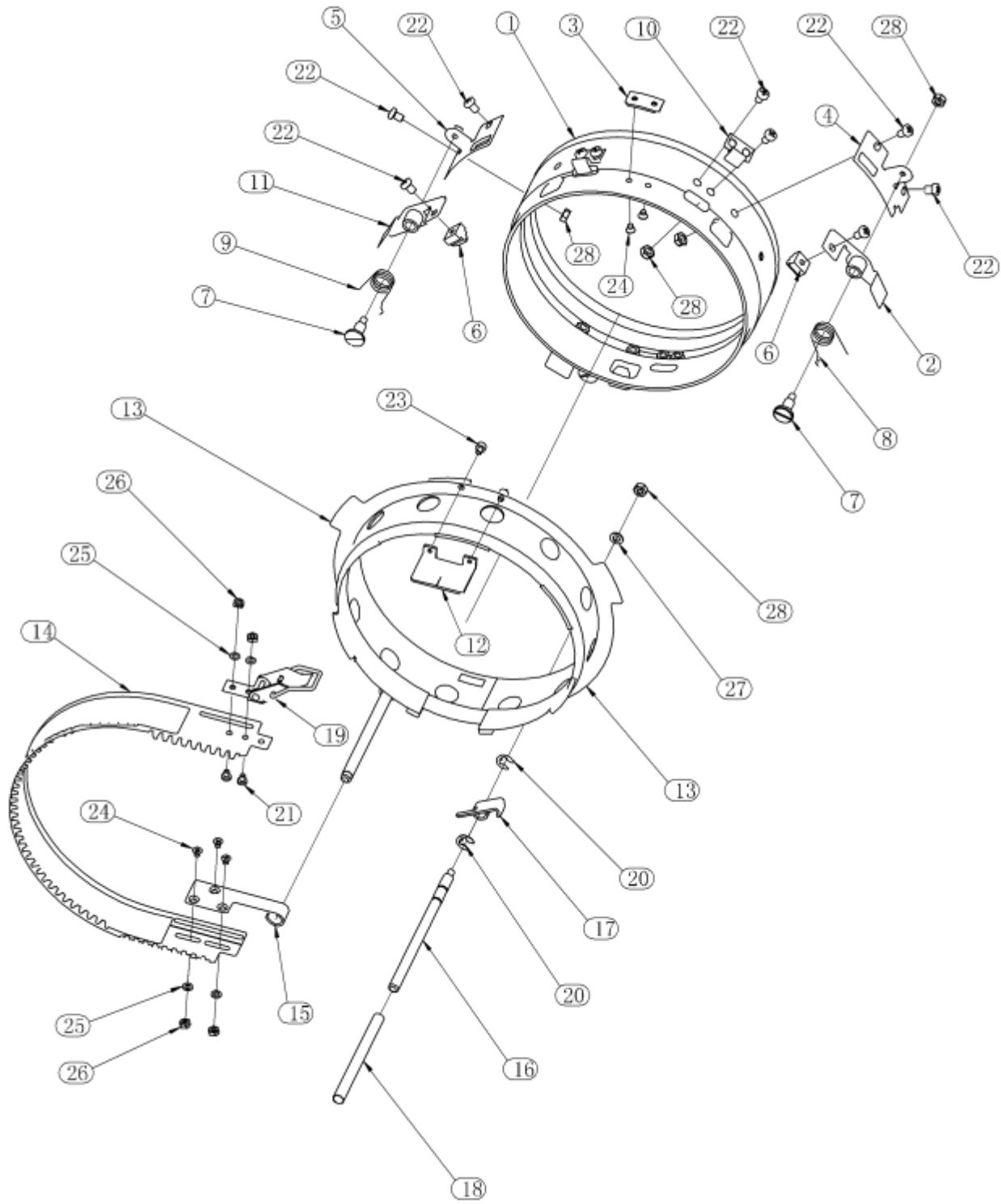

Cap Frame

Cap Frame. Reference picture on previous page

NO	Part #	Part Name	Remark
1	02810201	cap casing	
2	02810203	collar A	
3	02810204	positioning block	
4	02810211	clamp base A	
5	02810212	clamp base B	
6	02810213	clamp	
7	02810215	screw	
8	02810216	collar spring A	
9	02810217	collar spring B	
10	02810272	shrapnel	
11	02810281	collar B	
12	02811006	positioning block	
13	02811009	clamp ring	
14	02811010	cap strapping rod	
15	02811011	cap strapping rod	
16	02811012	cap clamp bracket	
17	02811019	tapered end hook	
18	02811031	rubber bushing	
19	02811081	tapered end	
20	80030671	E-ring	
21	80740304	M3x4 screw	
22	80740406	M4x6 screw	
23	80813304	M3x4 screw	
24	80860304	M3x4 screw	
25	80900301	M3 screw	
26	80900321	M3 nut	
27	80900408	M4 plain washer	
28	80900421	M4 nut	

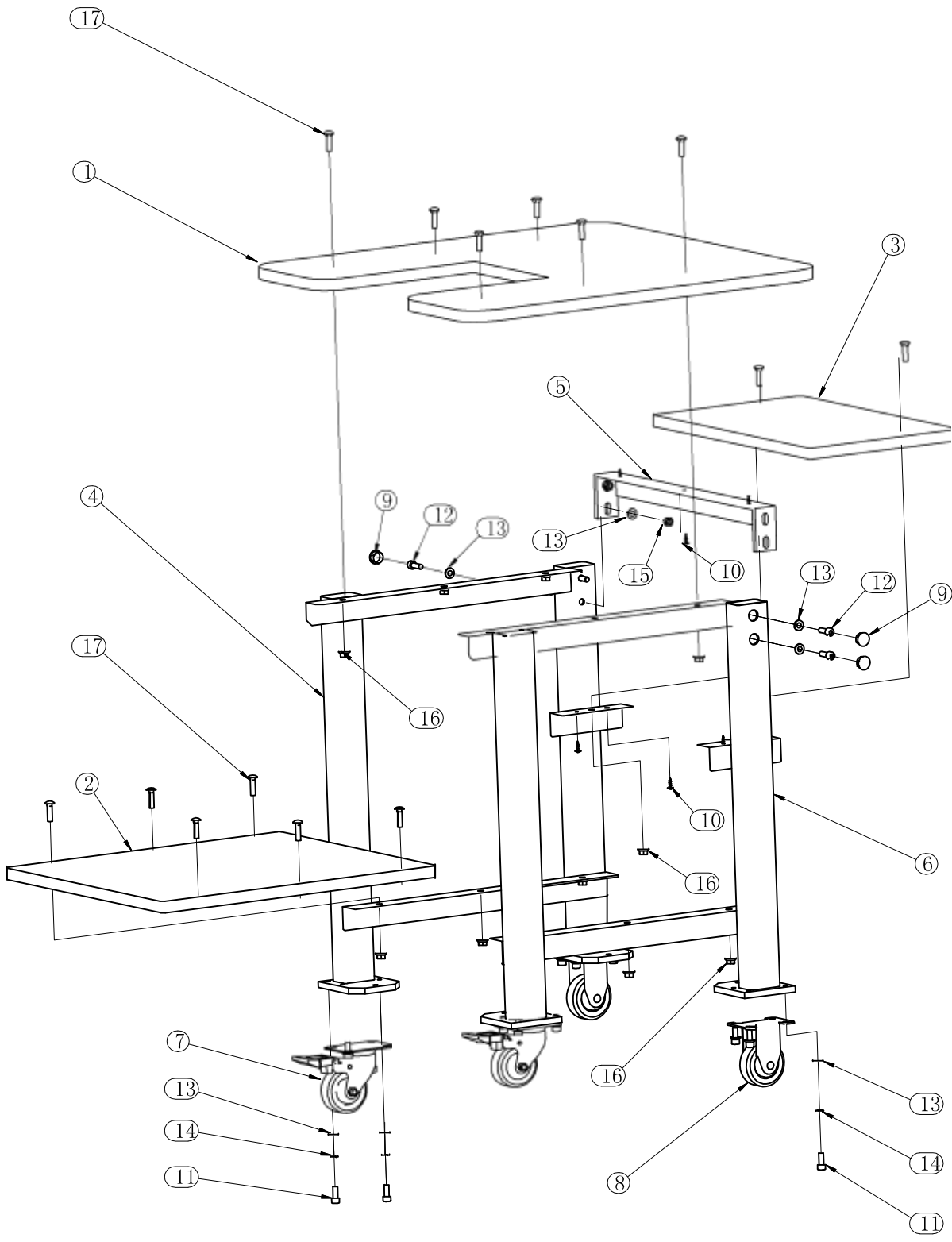

Cart

Cart. Reference picture on previous page

NO	Part #	Part Name	Remark
1	03010306	rack upper table	
2	03010307	rack middle table	
3	03010308	rack lower table	
4	03018001	rack-L	
5	03018002	rack beam	
6	03018003	rack-R	
7	80270304	rotary truckle	
8	80270305	fixed truckle	
9	80390901	pore plug	
10	80700121	4x16 screw	
11	80813816	M8x16 screw	
12	80813825	M8x25	
13	80900801	M8 plain washer	
14	80900818	M8 spring washer	
15	80900821	M8 nut	
16	80900824	M8 nut	
17	80920201	M8x30 bolt	